

PROVEN PERFORMANCE

Customers in over 60 countries and in diverse markets and sectors.



# Kinco

Motion Control  
Stepper System

## Stepper System Catalog

- Stepper Driver
- Stepper Motor



**Kinco® Automation**  
<http://www.kinco.cn> Email:sales@kinco.cn

(All trademarks and logos in this brochure are property of and registered by their respective owners.)

K1E09-2101

# CONTENTS

## Denomination rules / Selection table

- 02 Denomination rules/model list of stepper driver
- 04 Denomination rules/model list of stepper motor
- 06 Selection table of stepper driver&motor

## Stepper Driver

- 08 Stepper driver 2CM525
- 09 Stepper driver 2CM545
- 10 Stepper driver 2CM560
- 11 Stepper driver 2CM860
- 12 Stepper driver 2CM880
- 13 Stepper driver 3CM880
- 14 Stepper driver CM422B
- 15 Stepper driver CM422C
- 16 Stepper driver CM880A
- 17 stepper driver CM880B
- 18 stepper driver CM880C
- 19 stepper driver 2CM0870
- 20 Stepper driver 2M412
- 21 Stepper driver 2M1180N
- 22 Stepper driver 2M2280N
- 23 Stepper driver 2H1160
- 24 Stepper driver 3M2280N
- 25 CAN bus stepper driver FM860
- 27 CAN bus stepper driver FM560&FM880

## Stepper Motor

- 28 Two-phase stepper motor/42 series
- 30 Two-phase stepper motor/57 series
- 32 Two-phase stepper motor/86 series
- 34 Two-phase stepper motor/110 series
- 36 Two-phase stepper motor/130 series
- 37 Three-phase stepper motor/57 series
- 38 Three-phase stepper motor/85 series

## Selection and Installation

- 39 Calculation for stepper motor selection
- 40 Example for stepper motor selection
- 41 Installation instructions for stepper motors
- 42 Typical wiring diagram

# Denomination rules

## Denomination rules of stepper driver

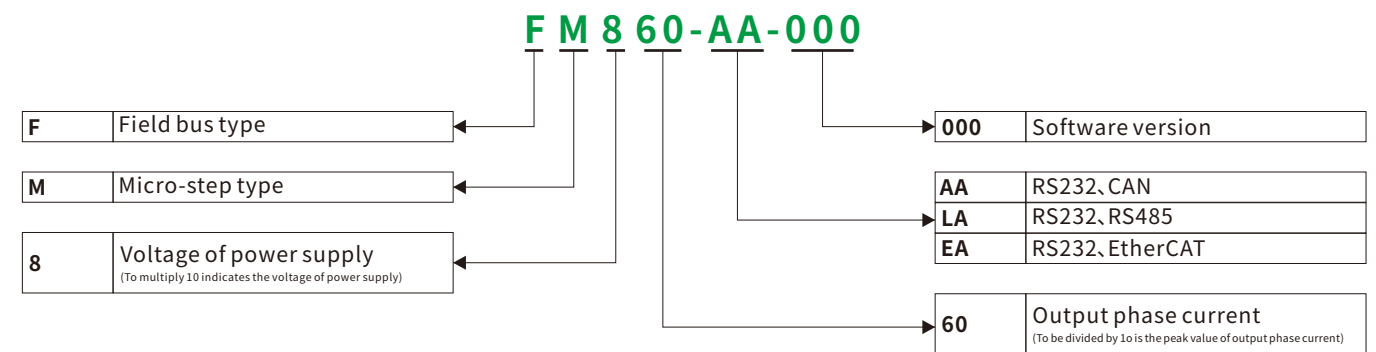
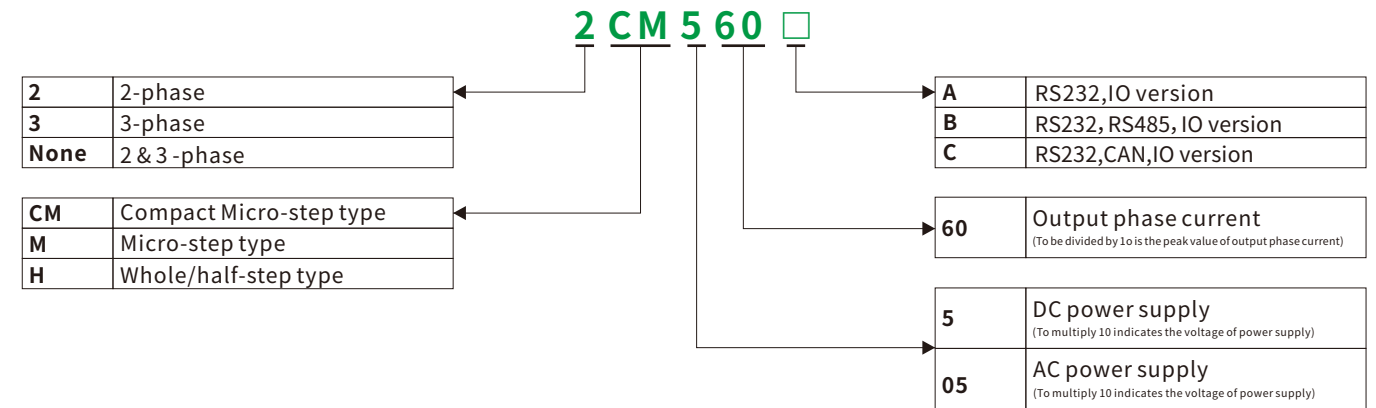

## Model list of stepper driver

Series No.	Phase	Model	Peak current	Voltage	Subdivision	Weight(Kg)	Dimension(mm)
CM Series	2-phase	2CM525	0.3~2.5A	24~50VDC	200~25600	0.25	118×75.5×25.4
	2-phase	2CM545	1.0~4.5A	24~50VDC	200~25600	0.25	
	2-phase	2CM560	1.8~6A	24~50VDC	200~25600	0.25	
	2-phase	2CM860	1.8~6A	24~70VDC	200~25600	0.25	
	2-phase	2CM880	2.4~8A	24~70VDC	200~25600	0.253	118×75.5×34
	2-phase	2CM0870	2.4~7.2A	18~80VAC	400~51200	0.696	151×97.5×57.5
	3-phase	3CM880	2.4~8A	24~70VDC	400~25600	0.253	118×75.5×34
	2&3-phase	CM422B	0.1~2.5A	12~40VDC	200~65535	0.11	93×56×21
	2&3-phase	CM422C	0.1~2.5A	12~40VDC	200~65535	0.11	93×56×21
	2&3-phase	CM880A	0.15~8A	24~70VDC	200~65535	0.29	108×75.5×34
	2&3-phase	CM880B	0.15~8A	24~70VDC	200~65535	0.253	108×75.5×34
	2&3-phase	CM880C	0.15~8A	24~70VDC	200~65535	0.253	108×75.5×34
M Series	2-phase	2M412	0.2~1.2A	12~40VDC	400~51200	0.13	76×60×35.2
	2-phase	2H1160	2.5~6.5A	60~123VAC	200~400	1.77	200×123×86.5
	2-phase	2M1180N	4.5~8A	77~123VAC	400~25600	1.5	201×147×66
		2M2280N	4.5~8A	220VAC±15%	400~25600	1.5	
3-phase	3M2280N	2.8~8A	220VAC±15%	400~20000	1.5		
Fseries	2&3-phase	FM860-LA-000	0.15~8A	24~70VDC	200~65535	0.36	134.5×75.5×34
		FM860-AA-000					
		FM880-EA-000	0.1~10A			0.36	

## Denomination rules

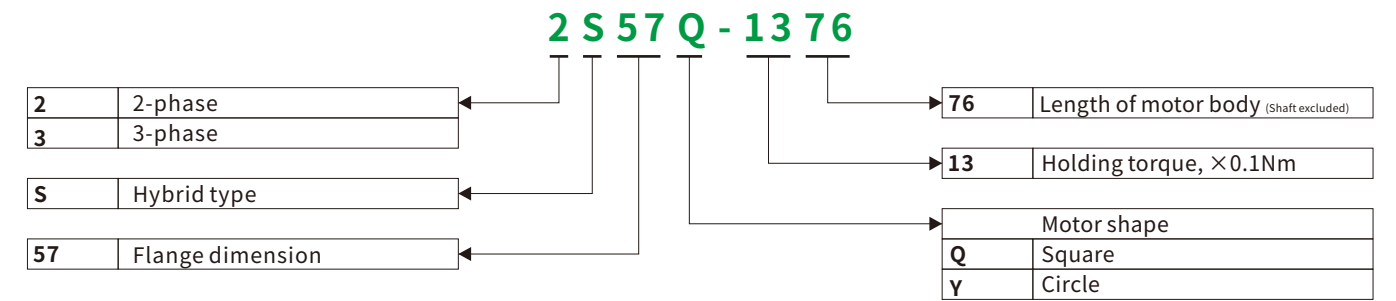

## Model list of stepper motor

Phase No.	Flange	Model	Holding torque (N.m)	Phase current (A)		Phase resistance (Ω)	Phase inductance (mH)	Inertia (Kg.cm <sup>2</sup> )	Lead No.	Shaft diameter (mm)	Shaft type	Length (mm)	Weight (Kg)	Step angle (°)
				Series	Parallel									
2-phase	42	2S42Q-0240	0.22	0.4		12.5±10%	21±20%	0.054	4	5	Without key	40	0.28	1.8
		2S42Q-0348	0.34	0.7	1.4	4.6±10%	4±20%	0.068	8	5	Without key	48	0.36	1.8
	57	2S57Q-0541	0.5	0.7	1.5	3.6±10%	4.1±20%	0.135	8	6.35	Platform	41	0.45	1.8
		2S57Q-0956	0.9	1.96	3.92	0.8±10%	1.2±20%	0.3	8	6.35	Platform	56	0.7	1.8
		2S57Q-1376	1.3	1.96	3.92	1±10%	2.1±20%	0.48	8	6.35	Platform	76	1	1.8
		2S57Q-2280	2.2	2.8	5.6	0.8±10%	1.8±20%	0.53	8	8	Platform	80	1.1	1.8
		2S57Q-25B2	2.5	2.9	6	1±10%	1.8±20%	0.8	8	8	Platform	112	1.7	1.8
	86	2S86Q-3465	3.4	6		0.3±10%	1.7±20%	1	4	13	Flat key	65	1.7	1.8
		2S86Q-4580	4.5	6		0.38±10%	3.5±20%	1.4	4	13	Flat key	80	2.3	1.8
		2S86Q-85B8	8.5	6		0.6±10%	6±20%	3.4	4	13	Flat key	118	3.7	1.8

## Denomination rules

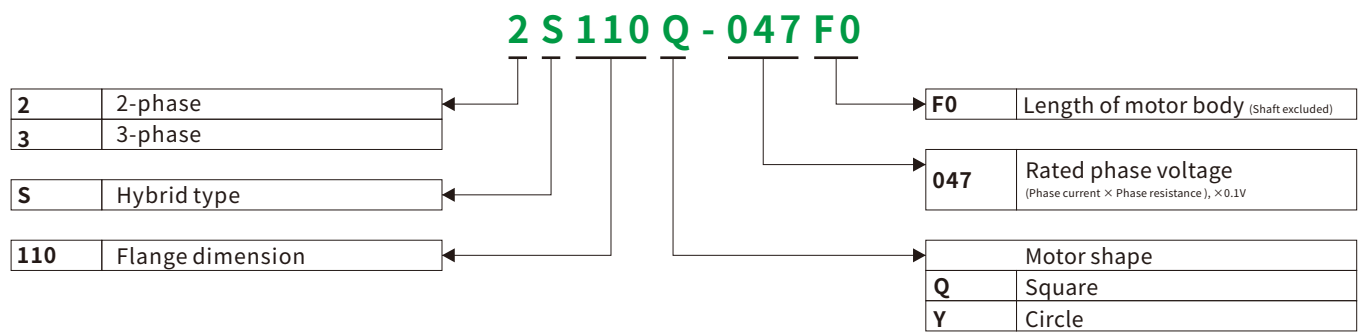

## Model list of stepper motor

Phase No.	Flange	Model	Holding torque (N.m)	Phase current (A)	Phase resistance (Ω)	Phase inductance (mH)	Inertia (Kg.cm <sup>2</sup> )	Lead No.	Shalf diameter (mm)	Shalf type	Length (mm)	Weight (Kg)	Step angle (°)
2-phase	86	2S86Q-051F6	12.8	6	0.85±10%	10±20%	4	4	15.875	Flat key	156	5.3	1.8
	110	2S110Q-03999	11.7	5.5	0.7±10%	9.8±20%	5.5	4	19	Flat key	99	5	1.8
		2S110Q-047F0	21	6.5	0.72±10%	12.8±20%	10.9	4	19	Flat key	150	8.4	1.8
		2S110Q-054K1	30	8	0.67±10%	11±20%	16.2	4	19	Flat key	201	11.7	1.8
	130	2S130Y-039M0	27	6	0.65±10%	13.8±20%	33.3	4	19	Flat key	165	13	1.8
		2S130Y-063R8	40	7	0.9±10%	9.5±20%	48.4	4	19	Flat key	230	19	1.8
3-phase	57	3S57Q-04056	0.9	5.6	0.7±10%	1.7±20%	0.3	4	6.35	Without key	56	0.72	1.2
		3S57Q-04079	1.5	5.8	1.05±10%	2.4±20%	0.48	4	8	Without key	79	1	1.2
	85	3S85Q-04097	4	5.8	1.1±10%	4.6±20%	2.32	4	12	Crescent key	97	2.7	1.2
		3S85Q-040F7	7.5	4	1.78±10%	17.1±20%	0.44	4	14	Flat key	157±1	5.3	1.2

## Selection table of stepper driver & motor

Control mode	Pulse control						I/O control	Pulse control					Field bus control AA: CANopen LA: RS485
	2CM525	2CM545	2CM560	2CM860	2CM880	3CM880		CM880A	2M412*	2H1160*	2M1180N	2M2280N	
Driver													
Motor													
2S42Q-0240	√						√	√					√
2S42Q-0348	√						√	√					√
2S57Q-0541	√						√						√
2S57Q-0956		√	√	√			√						√
2S57Q-1376		√	√	√			√						√
2S57Q-2280			√	√	√		√						√
2S57Q-25B2			√	√	√		√						√
2S86Q-3465					√		√		√	√			√
2S86Q-4580					√		√		√	√			√
2S86Q-85B8					√		√		√	√			√
2S86Q-051F6					√		√		√	√			√
2S110Q-03999									√	√	√		
2S110Q-047F0									√	√	√		
2S110Q-054K1									√	√	√		
2S130Y-039M0											√		
2S130Y-063R8											√		
3S57Q-04056						√	√						√
3S57Q-04079						√	√						√
3S85Q-04097						√	√						√
3S85Q-040F7												√	

Note: √ indicates recommended motor model.  
 \* Except 2M412 & 2H1160, other driver models could driver the third-party motors.





# Stepper Driver 2CM545

# Stepper Driver 2CM560



- Support parameter self-adaptive function, generate optimal parameters according to motor type, ensure motor run at optimal performance;
- Phase memory function;
- Automatic half-current function, selected by DIP switches;
- Test running function, selected by DIP switches;
- Over voltage protection, over current protection functions;
- Micro-step filter function can smooth input pulse to reduce transient motion of motor, make sure motor run more smoothly;
- Opto-isolation ERR signal output with max. current of 100mA;
- Opto-isolation 5-24V pulse input, responding frequency up 400KHz;
- 15 subdivision levels and 8 current levels are selectable by DIP switches;
- Pulse type is selectable by DIP switches: PUL+DIR&CW/CCW.

- Support parameter self-adaptive function, generate optimal parameters according to motor type, ensure motor run at optimal performance;
- Phase memory function;
- Automatic half-current function, selected by DIP switches;
- Test running function, selected by DIP switches;
- Over voltage protection, over current protection functions;
- Micro-step filter function can smooth input pulse to reduce transient motion of motor, make sure motor run more smoothly;
- Opto-isolation ERR signal output with max. current of 100mA;
- Opto-isolation 5-24V pulse input, responding frequency up 400KHz;
- 15 subdivision levels and 8 current levels are selectable by DIP switches;
- Pulse type is selectable by DIP switches: PUL+DIR&CW/CCW.

## Mechanical Dimensions (Unit:mm)

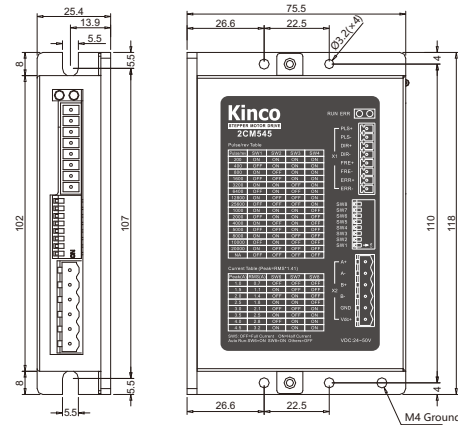

## Mechanical Dimensions (Unit:mm)

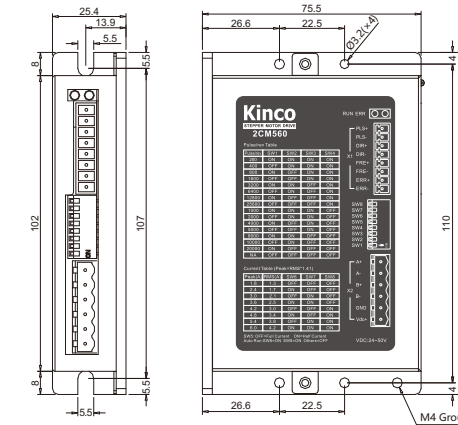

## Technical Specifications

Input voltage	24~50VDC	
Overvoltage protection	85VDC	
Undervoltage protection	15VDC	
Overheat protection	85°C(Temperature of thermistor)	
Phase current(Peak)	1/1.5/2/2.5/3/3.5/4/4.5, 8 settable values in total. (Unit: A)	
Subdivision	200~25600 Pulse/rev, 15 subdivision levels in total	
Adaptable motor	57 series 2-phase hybrid stepper motor	
Input signal	PLS (CW) , DIR(CCW), FREE, Input voltage:5~24VDC, Input current:8mA@5VDC, 12mA@24VDC	
Control mode	Pulse control:PLS+DIR, CW/CCW	
Output signal	ERR, open collector output, maximum current:100mA	
Operation indicator	Combination of RUN and ERR LED indicates different status	
Protection circuit	Over voltage, under voltage, over current, over heat	
Cooling method	Nature air cooling	
Environment	Operation environment	Avoid environment with great amount of metallic powder, oil mist, or erosive gases
	Operation humidity	<85%, RH(Non-condensing or water drops)
	Operation temperature	0°C~+40°C
	Storage temperature	-20°C~+70°C
Weight(Net)	0.25kg	
Dimensions	118×75.5×25.4 mm (Toothless heat sink)	
Ingress protection	IP20	

## Technical Specifications

Input voltage	24~50VDC	
Overvoltage protection	85VDC	
Undervoltage protection	15VDC	
Overheat protection	80°C(Temperature of thermistor)	
Phase current(Peak)	1.8/2.4/3/3.6/4.2/4.8/5.4/6, 8 settable values in total. (Unit: A)	
Subdivision	200~25600 Pulse/rev, 15 subdivision levels in total	
Adaptable motor	57 series 2-phase hybrid stepper motor	
Input signal	PLS, DIR, FREE, Input voltage:5~24VDC, Input current:8mA@5VDC, 12mA@24VDC	
Control mode	Pulse control:PLS+DIR, CW/CCW	
Output signal	ERR, open collector output, maximum current:100mA	
Operation indicator	Combination of RUN and ERR LED indicates different status	
Protection circuit	Over voltage, under voltage, over current, over heat	
Cooling method	Nature air cooling	
Environment	Operation environment	Avoid environment with great amount of metallic powder, oil mist, or erosive gases
	Operation humidity	<85%, RH(Non-condensing or water drops)
	Operation temperature	0°C~+40°C
	Storage temperature	-20°C~+70°C
Weight(Net)	0.25kg	
Dimensions	118×75.5×25.4 mm (Toothless heat sink)	
Ingress protection	IP20	

## Function of DIP switches

Function	DIP setting	Description
PLS+DIR	SW6,SW7=ON; Others=OFF	Set DIP switches according to functions required when power off. Power on driver, RUN LED blinking in green, ERR LED is red. It means settings take effect. Then power off driver, reset subdivision and current for normal use.
CW/CCW	SW7,SW8=ON; Others=OFF	
Micro-step smooth & dynamic filter disable	SW5,SW6=ON; Others=OFF	
Micro-step smooth filter enable	SW5,SW7=ON; Others=OFF	
Micro-step dynamic filter enable	SW5,SW8=ON; Others=OFF	
Test motor parameter upon power on disable	SW6,SW7,SW8=ON; Others=OFF	
Test motor parameter upon power on enable	SW5,SW6,SW7=ON; Others=OFF	
Test running	SW6,SW8=ON; Others=OFF	Motor running @80RPM
Automatic half-current	SW5=ON	Set SW5=ON to enable automatic half-current. Phase current will reduce to half of the set value after motor stops for 1.5s

## Function of DIP switches

Function	DIP setting	Description
PLS+DIR	SW6,SW7=ON; Others=OFF	Set DIP switches according to functions required when power off. Power on driver, RUN LED blinking in green, ERR LED is red. It means settings take effect. Then power off driver, reset subdivision and current for normal use.
CW/CCW	SW7,SW8=ON; Others=OFF	
Micro-step smooth & dynamic filter disable	SW5,SW6=ON; Others=OFF	
Micro-step smooth filter enable	SW5,SW7=ON; Others=OFF	
Micro-step dynamic filter enable	SW5,SW8=ON; Others=OFF	
Test motor parameter upon power on disable	SW6,SW7,SW8=ON; Others=OFF	
Test motor parameter upon power on enable	SW5,SW6,SW7=ON; Others=OFF	
Test running	SW6,SW8=ON; Others=OFF	Motor running @80RPM
Automatic half-current	SW5=ON	Set SW5=ON to enable automatic half-current. Phase current will reduce to half of the set value after motor stops for 1.5s

Subdivision setting (Unit:PULSE/REV)					Current setting (Unit: A)				
SW1	SW2	SW3	SW4=ON	SW4=OFF	SW6	SW7	SW8	RMS	Peak
ON	ON	ON	200	1000	ON	ON	ON	3.2	4.5
OFF	ON	ON	400	2000	OFF	ON	ON	2.8	4
ON	OFF	ON	800	4000	ON	OFF	ON	2.5	3.5
OFF	OFF	ON	1600	5000	OFF	OFF	ON	2.1	3
ON	ON	OFF	3200	8000	ON	ON	OFF	1.8	2.5
OFF	ON	OFF	6400	10000	OFF	ON	OFF	1.4	2
ON	OFF	OFF	12800	20000	ON	OFF	OFF	1.1	1.5
OFF	OFF	OFF	25600	NA	OFF	OFF	OFF	0.7	1

Subdivision setting (Unit:PULSE/REV)					Current setting (Unit: A)				
SW1	SW2	SW3	SW4=ON	SW4=OFF	SW6	SW7	SW8	RMS	Peak
ON	ON	ON	200	1000	ON	ON	ON	4.2	6
OFF	ON	ON	400	2000	OFF	ON	ON	3.8	5.4
ON	OFF	ON	800	4000	ON	OFF	ON	3.4	4.8
OFF	OFF	ON	1600	5000	OFF	OFF	ON	3	4.2
ON	ON	OFF	3200	8000	ON	ON	OFF	2.5	3.6
OFF	ON	OFF	6400	10000	OFF	ON	OFF	2.1	3
ON	OFF	OFF	12800	20000	ON	OFF	OFF	1.7	2.4
OFF	OFF	OFF	25600	NA	OFF	OFF	OFF	1.3	1.8

# Stepper Driver 2CM860



- Support parameter self-adaptive function, generate optimal parameters according to motor type, ensure motor run at optimal performance;
- Phase memory function;
- Automatic half-current function, selected by DIP switches;
- Test running function, selected by DIP switches;
- Over voltage protection, over current protection functions;
- Micro-step filter function can smooth input pulse to reduce transient motion of motor, make sure motor run more smoothly;
- Opto-isolation ERR signal output with max. current of 100mA;
- Opto-isolation 5-24V pulse input, responding frequency up 400KHz;
- 15 subdivision levels and 8 current levels are selectable by DIP switches;
- Pulse type is selectable by DIP switches: PUL+DIR&CW/CCW.

## Mechanical Dimensions (Unit:mm)

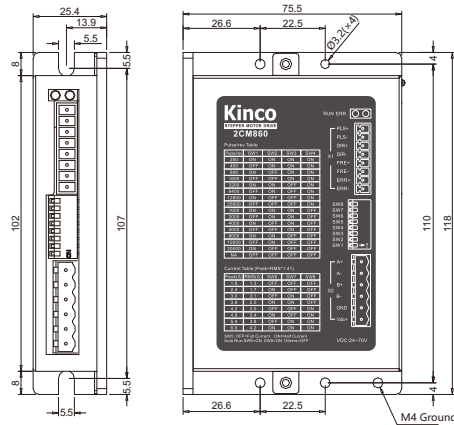

## Function of DIP switches

Function	DIP setting	Description
PLS+DIR	SW6,SW7=ON; Others=OFF	Set DIP switches according to functions required when power off. Power on driver, RUN LED blinking in green, ERR LED is red. It means settings take effect. Then power off driver, reset subdivision and current for normal use.
CW/CCW	SW7,SW8=ON; Others=OFF	
Micro-step smooth & dynamic filter disable	SW5,SW6=ON; Others=OFF	
Micro-step smooth filter enable	SW5,SW7=ON; Others=OFF	
Micro-step dynamic filter enable	SW5,SW8=ON; Others=OFF	
Test motor parameter upon power on disable	SW6,SW7,SW8=ON; Others=OFF	Test motor parameter upon power on enable
Test motor parameter upon power on enable	SW5,SW6,SW7=ON; Others=OFF	
Test running	SW6,SW8=ON; Others=OFF	Motor running @80RPM
Automatic half-current	SW5=ON	Set SW5=ON to enable automatic half-current. Phase current will reduce to half of the set value after motor stops for 1.5s

## Technical Specifications

Input voltage	24~70VDC	
Overvoltage protection	85VDC	
Undervoltage protection	15VDC	
Overheat protection	80°C(Temperature of thermistor)	
Phase current(Peak)	1.8/2.4/3/3.6/4.2/4.8/5.4/6, 8 settable values in total. (Unit: A)	
Subdivision	200~25600 Pulse/rev, 15 subdivision levels in total	
Adaptable motor	57 series 2-phase hybrid stepper motor	
Input signal	PLS, DIR, FREE, Input voltage:5~24VDC, Input current:8mA@5VDC, 12mA@24VDC	
Control mode	Pulse control:PLS+DIR, CW/CCW	
Output signal	ERR, open collector output, maximum current:100mA	
Operation indicator	Combination of RUN and ERR LED indicates different status	
Protection circuit	Over voltage, under voltage, over current, over heat	
Cooling method	Nature air cooling	
Environment	Operation environment	Avoid environment with great amount of metallic powder, oil mist, or erosive gases
	Operation humidity	<85%, RH(Non-condensing or water drops)
	Operation temperature	0°C~+40°C
	Storage temperature	-20°C~+70°C
Weight(Net)	0.25kg	
Dimensions	118×75.5×25.4 mm (Toothless heat sink)	
Ingress protection	IP20	

Subdivision setting (Unit:PULSE/REV)					Current setting (Unit: A)				
SW1	SW2	SW3	SW4=ON	SW4=OFF	SW6	SW7	SW8	RMS	Peak
ON	ON	ON	200	1000	ON	ON	ON	4.2	6
OFF	ON	ON	400	2000	OFF	ON	ON	3.8	5.4
ON	OFF	ON	800	4000	ON	OFF	ON	3.4	4.8
OFF	OFF	ON	1600	5000	OFF	OFF	ON	3	4.2
ON	ON	OFF	3200	8000	ON	ON	OFF	2.5	3.6
OFF	ON	OFF	6400	10000	OFF	ON	OFF	2.1	3
ON	OFF	OFF	12800	20000	ON	OFF	OFF	1.7	2.4
OFF	OFF	OFF	25600	NA	OFF	OFF	OFF	1.3	1.8

# Stepper Driver 2CM880



- Support parameter self-adaptive function, generate optimal parameters according to motor type, ensure motor run at optimal performance;
- Phase memory function;
- Automatic half-current function, selected by DIP switches;
- Test running function, selected by DIP switches;
- Over voltage protection, over current protection functions;
- Micro-step filter function can smooth input pulse to reduce transient motion of motor, make sure motor run more smoothly;
- Opto-isolation ERR signal output with max. current of 100mA;
- Opto-isolation 5-24V pulse input, responding frequency up 400KHz;
- 15 subdivision levels and 8 current levels are selectable by DIP switches;
- Pulse type is selectable by DIP switches: PUL+DIR&CW/CCW.

## Mechanical Dimensions (Unit:mm)

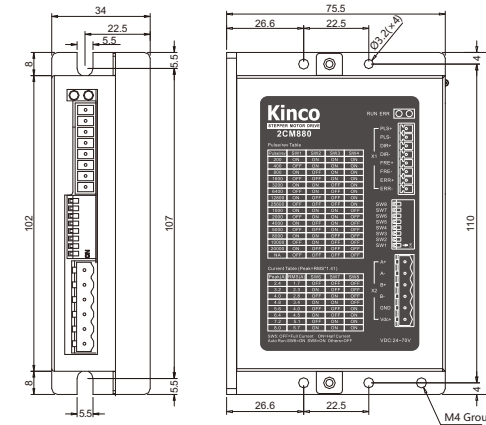

## Function of DIP switches

Function	DIP setting	Description
PLS+DIR	SW6,SW7=ON; Others=OFF	Set DIP switches according to functions required when power off. Power on driver, RUN LED blinking in green, ERR LED is red. It means settings take effect. Then power off driver, reset subdivision and current for normal use.
CW/CCW	SW7,SW8=ON; Others=OFF	
Micro-step smooth & dynamic filter disable	SW5,SW6=ON; Others=OFF	
Micro-step smooth filter enable	SW5,SW7=ON; Others=OFF	
Micro-step dynamic filter enable	SW5,SW8=ON; Others=OFF	
Test motor parameter upon power on disable	SW6,SW7,SW8=ON; Others=OFF	Test motor parameter upon power on enable
Test motor parameter upon power on enable	SW5,SW6,SW7=ON; Others=OFF	
Test running	SW6,SW8=ON; Others=OFF	Motor running @80RPM
Automatic half-current	SW5=ON	Set SW5=ON to enable automatic half-current. Phase current will reduce to half of the set value after motor stops for 1.5s

## Technical Specifications

Input voltage	24~70VDC	
Overvoltage protection	85VDC	
Undervoltage protection	15VDC	
Overheat protection	80°C(Temperature of thermistor)	
Phase current(Peak)	2.4/3.2/4/4.8/5.6/6.4/7.2/8, 8 settable values in total. (Unit: A)	
Subdivision	200~25600 Pulse/rev, 15 subdivision levels in total	
Adaptable motor	57/86 series 2-phase hybrid stepper motor	
Input signal	PLS, DIR, FREE, Input voltage:5~24VDC, Input current:8mA@5VDC, 12mA@24VDC	
Control mode	Pulse control:PLS+DIR, CW/CCW	
Output signal	ERR, open collector output, maximum current:100mA	
Operation indicator	Combination of RUN and ERR LED indicates different status	
Protection circuit	Over voltage, under voltage, over current, over heat	
Cooling method	Nature air cooling	
Environment	Operation environment	Avoid environment with great amount of metallic powder, oil mist, or erosive gases
	Operation humidity	<85%, RH(Non-condensing or water drops)
	Operation temperature	0°C~+40°C
	Storage temperature	-20°C~+70°C
Weight(Net)	0.253kg	
Dimensions	118×75.5×34 mm (Toothed heat sink)	
Ingress protection	IP20	

Subdivision setting (Unit:PULSE/REV)					Current setting (Unit: A)				
SW1	SW2	SW3	SW4=ON	SW4=OFF	SW6	SW7	SW8	RMS	Peak
ON	ON	ON	200	1000	ON	ON	ON	5.7	8
OFF	ON	ON	400	2000	OFF	ON	ON	5.1	7.2
ON	OFF	ON	800	4000	ON	OFF	ON	4.5	6.4
OFF	OFF	ON	1600	5000	OFF	OFF	ON	4	5.6
ON	ON	OFF	3200	8000	ON	ON	OFF	3.4	4.8
OFF	ON	OFF	6400	10000	OFF	ON	OFF	2.8	4
ON	OFF	OFF	12800	20000	ON	OFF	OFF	2.3	3.2
OFF	OFF	OFF	25600	NA	OFF	OFF	OFF	1.7	2.4



# Stepper Driver 3CM880

# Stepper Driver CM422B



- Support parameter self-adaptive function, generate optimal parameters according to motor type, ensure motor run at optimal performance;
- Phase memory function;
- Automatic half-current function, selected by DIP switches;
- Test running function, selected by DIP switches;
- Over voltage protection, over current protection functions;
- Micro-step filter function can smooth input pulse to reduce transient motion of motor, make sure motor run more smoothly;
- Opto-isolation ERR signal output with max. current of 100mA;
- Opto-isolation 5-24V pulse input, responding frequency up 400KHz;
- 15 subdivision levels and 8 current levels are selectable by DIP switches;
- Pulse type is selectable by DIP switches: PUL+DIR&CW/CCW.

## Mechanical Dimensions (Unit:mm)

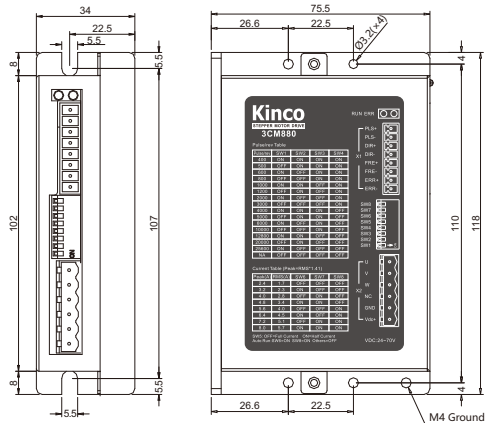

## Technical Specifications

Input voltage	24~70VDC
Overvoltage protection	85VDC
Undervoltage protection	15VDC
Overheat protection	80°C(Temperature of thermistor)
Phase current(Peak)	2.4/3.2/4/4.8/5.6/6.4/7.2/8, 8 settable values in total. (Unit: A)
Subdivision	400~25600 Pulse/rev, 15 subdivision levels in total
Adaptable motor	3-phase hybrid stepper motor
Input signal	PLS, DIR, FREE, Input voltage:5~24VDC, Input current:8mA@5VDC, 12mA@24VDC
Control mode	Pulse control:PLS+DIR, CW/CCW
Output signal	ERR, open collector output, maximum current:100mA
Operation indicator	Combination of RUN and ERR LED indicates different status
Protection circuit	Over voltage, under voltage, over current, over heat
Cooling method	Nature air cooling
Environment	Operation environment Avoid environment with great amount of metallic powder, oil mist, or erosive gases
	Operation humidity <85%, RH(Non-condensing or water drops)
	Operation temperature 0°C~+40°C
	Storage temperature -20°C~+70°C
Weight(Net)	0.253kg
Dimensions	118×75.5×34 mm (Toothed heat sink)
Ingress protection	IP20

Subdivision setting (Unit:PULSE/REV)					Current setting (Unit: A)				
SW1	SW2	SW3	SW4=ON	SW4=OFF	SW6	SW7	SW8	RMS	Peak
ON	ON	ON	400	4000	ON	ON	ON	5.7	8
OFF	ON	ON	500	5000	OFF	ON	ON	5.1	7.2
ON	OFF	ON	600	6000	ON	OFF	ON	4.5	6.4
OFF	OFF	ON	800	10000	OFF	OFF	ON	4	5.6
ON	ON	OFF	1000	12800	ON	ON	OFF	3.4	4.8
OFF	ON	OFF	1200	20000	OFF	ON	OFF	2.8	4
ON	OFF	OFF	2000	25600	ON	OFF	OFF	2.3	3.2
OFF	OFF	OFF	3000	NA	OFF	OFF	OFF	1.7	2.4

## Function of DIP switches

Function	DIP setting	Description
PLS+DIR	SW6,SW7=ON; Others=OFF	Set DIP switches according to functions required when power off. Power on driver, RUN LED blinking in green, ERR LED is red. It means settings take effect. Then power off driver, reset subdivision and current for normal use.
CW/CCW	SW7,SW8=ON; Others=OFF	
Micro-step smooth & dynamic filter disable	SW5,SW6=ON; Others=OFF	
Micro-step smooth filter enable	SW5,SW7=ON; Others=OFF	
Micro-step dynamic filter enable	SW5,SW8=ON; Others=OFF	
Test motor parameter upon power on disable	SW6,SW7,SW8=ON; Others=OFF	
Test motor parameter upon power on enable	SW5,SW6,SW7=ON; Others=OFF	Motor running @80RPM
Test running	SW6,SW8=ON; Others=OFF	
Automatic half-current	SW5=ON	Set SW5=ON to enable automatic half-current. Phase current will reduce to half of the set value after motor stops for 1.5s



- 3 opto-isolation digital signal input channels, 3 channels support voltage range 5~24VDC;
- Support CW/CCW, PLS+DIR;
- Non-isolation RS485 interfaces, support Modbus protocol;
- Multiple I/O functions, support homing, multi-speed, multi-position,etc;
- Support automatic parameter adjustable regulation, self-defined shalf-lock, step smooth filter;
- Over-voltage, under-voltage, overheat and over-current protection;
- Support external UTC-SA or RS232-to-RS485 module, parameter settings by KincoStep software.

## Mechanical Dimensions (Unit:mm)

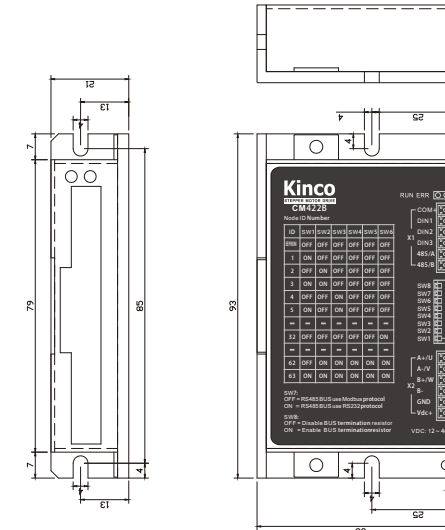

## Technical Specifications

Input voltage	12 ~ 40VDC
Overvoltage protection	45VDC
Undervoltage protection	9VDC
Phase current(Peak)	0.1A ~ 2.5A (Peak)
Subdivision	Set by KincoStep™ software
Node ID	Set by DIP switches SW1 ~ Sw6
Adaptable motor	42 series and under 42 series 2&3 phase hybrid stepper motor
Control mode	I/O control; Modbus control; Pulse control: PLS+DIR, CW/CCW
Cooling method	Natural air cooling
Operation environment	Avoid the environment with a great amount of metallic powder, oil mist, or erosive gases.
Operation humidity	<85%, RH(non-condensing or water drops)
Operation temperature	0°C ~ 40°C
Storage temperature	-20°C ~ 70°C
Weight	0.11kg
Dimensions	93X56X21mm
Ingress protection	IP20

## Interface Introduction

	Interface		Function
X1 I/O	COM+	Common anode port of DIN	Voltage: 5~24VDC Current: 8mA@5VDC, 12mA@24VDC Valid signal: For DINX, COM+, >3VDC Invalid signal: For DINX, COM+, <1VDC RS485 interface, non-isolation inside, Common GND between drivers
	DIN1	DIN1 negative	
	DIN2	DIN2 negative	
	DIN3	DIN3 negative	
	485/A	Differential RS485 signal input	
X2 Power interface	485/B	Differential RS485 signal input	Drive motor
	A+/U	Motor A+/U	
	A-/V	Motor A-/U	
	B+/W	Motor B+/W	
	B-	Motor B-	
GND	Power input-	Power input DC12~40V	
VDC	Power input+		

Note: (1) DIN1 and DIN2 use high-speed opto-isolation, max input frequency is 200KHz, min pulse width is 3us  
(2) DIN3 uses low-speed opto-isolation, max input frequency is 1KHz



# Stepper Driver CM422C

# Stepper Driver CM880A



- 3 opto-isolation digital signal input channels, 3 channels support voltage range 5~24VDC;
- Support CW/CCW, PLS+DIR;
- Non-isolation CAN interfaces, support CANopen;
- Multiple I/O functions, support homing, multi-speed, multi-position, etc;
- Support automatic parameter adjustable regulation, self-defined shalf-lock, step smooth filter;
- Micro-step filter function can smooth input pulse to reduce transient motion of motor, make sure motor run more smoothly;
- Over-voltage, under-voltage, overheat and over-current protection;
- Support external UTC-SA or RS232-to-RS485 module, parameter settings by KincoStep software.



- 6 opto-isolation digital signal input channels, 3 channels support voltage range 5~24VDC;
- 1 opto-isolation digital signal output channel, max current 100mA;
- Support CW/CCW, PLS+DIR, A+B phase signal;
- Multiple IO functions, supporting homing, multi-speed, multi-position and so on;
- Support motor parameter self-adaptive, self-defined shalf lock current, self-defined micro-step filter function;
- Powerful protection function: over voltage, under voltage, over heat, over current protection;
- Support RS232 communication, parameter settings via KincoStep software.

## Mechanical Dimensions (Unit:mm)

## Technical Specifications

## Mechanical Dimensions (Unit:mm)

## Technical Specifications

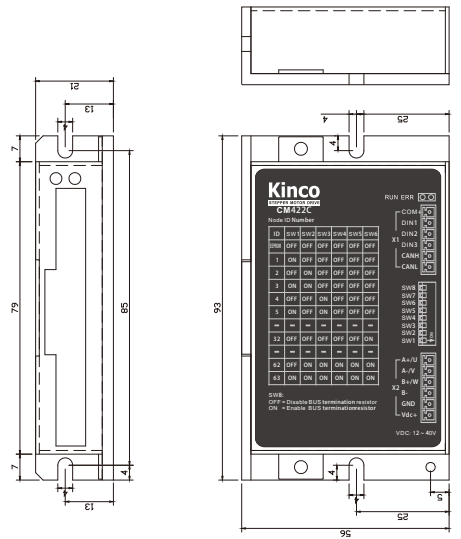

Input voltage	12 ~ 40VDC
Overvoltage protection	45VDC
Undervoltage protection	9VDC
Phase current(Peak)	0.1A ~ 2.5A (Peak)
Subdivision	Set by KincoStep software
Node ID	Set by DIP switches SW1 ~ SW6
Adaptable motor	42 series and under 42 series 2&3 phase hybrid stepper motor
Control mode	I/O control; CANopen control; Pulse control: PLS+DIR, CW/CCW
Cooling method	Natural air cooling
Operation environment	Avoid the environment with a great amount of metallic powder, oil mist, or erosive gases.
Operation humidity	<85%, RH(non-condensing or water drops)
Operation temperature	0°C ~ 40°C
Storage temperature	-20°C ~ 70°C
Weight	0.11kg
Dimensions	93X56X21mm
Ingress protection	IP20

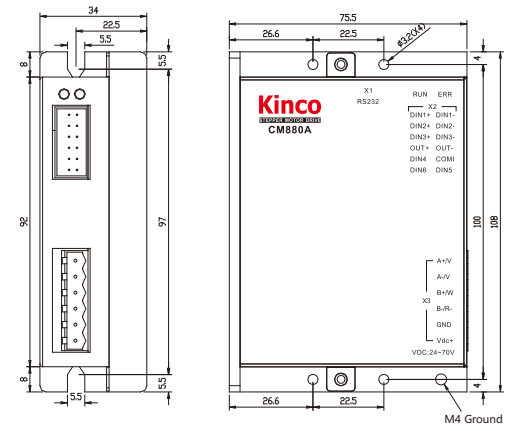

Input voltage	24~70VDC
Over voltage protection	85VDC
Under voltage protection	15VDC
Output current	0.15~8A (Peak)
Subdivision	Set by "KincoStep" software
Adaptable motor	2-phase & 3-phase hybrid stepper motor
Control mode	I/O control; Pulse control: PLS+DIR, CW/CCW, A+B phase
Cooling method	Nature air cooling
Operation environment	Avoid environment with great amount of metallic powder, oil mist, or erosive gases.
Environment humidity	<85%, RH (Non-condensing or water drops)
Environment temperature	0°C~+40°C
Storage temperature	-20°C~+70°C
Weight(Net)	0.29kg
Dimensions	108×75.5×34 mm (Toothed heat sink)
Ingress protection	IP20

## Interface Introduction

## Interface Introduction

Interface		Function
X1 I/O	COM+	Common anode port of DIN
	DIN1	DIN1 negative
	DIN2	DIN2 negative
	DIN3	DIN3 negative
	CANH CANL	Differential CAN signal input Motor A+/U Motor A-/U
X2 Power interface	A+/U	Motor A-/U
	A-/U	Motor B+/W
	B+/W	Motor B-
	B-	Power input-
	GND VDC	Power input+ Power input DC12~40V

Interface		Function
X1	RS232	RS232 interface
X2 IO interface	DIN1+	DIN1 positive input
	DIN1-	DIN1 negative input
	DIN2+	DIN2 positive input
	DIN2-	DIN2 negative input
	DIN3+	DIN3 positive input
	DIN3-	DIN3 negative input
	DIN4	DIN4 input
	DIN5	DIN5 input
	DIN6	DIN6 input
	COMI	COM of DIN4, DIN5, DIN6
OUT+	OUT positive input	
OUT-	OUT negative input	

Note:(1) DIN1 and DIN2 use high-speed opto-isolation, max input frequency is 200KHz, min pulse width is 3us  
(2) DIN3 uses low-speed opto-isolation, max input frequency is 1KHz

Note: (1) DIN1&DIN2 adopt high-speed opto-coupler, max. input frequency is 400KHz, min. pulse width is 1us.  
(2) DIN3~6 adopt low-speed opto-coupler, max. input frequency is 10KHz.  
(3) OUT adopts low-speed opto-coupler, max. output frequency is 1KHz

# Stepper Driver CM880B

# Stepper Driver CM880C



- 3 opto-isolation digital signal input channels, 3 channels support voltage range 5~24VDC;
- Support CW/CCW, PLS+DIR;
- Non-isolation RS485 interfaces, support Modbus protocol;
- Multiple I/O functions, support homing, multi-speed, multi-position, etc;
- Support automatic parameter adjustable regulation, self-defined half-lock, step smooth filter;
- Over-voltage, under-voltage, overheat and over-current protection;
- Support RS232 communication, parameter settings by KincoStep software.

## Mechanical Dimensions (Unit:mm)

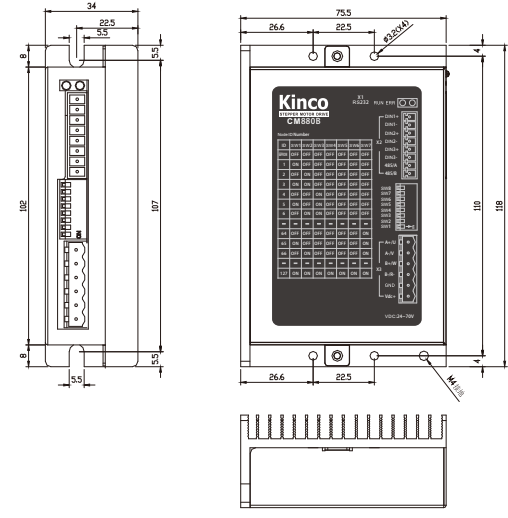

## Technical Specifications

Input voltage	24 ~ 70VDC
Over voltage protection	85VDC
Under voltage protection	15VDC
Output current	0.15 ~ 8A (Peak)
Subdivision	Set by KincoStep software
Adaptable motor	2&3 phase hybrid stepper motor
Control mode	I/O control; Modbus control; Pulse control: PLS+DIR, CW/CCW
Cooling method	Natural air cooling
Operation environment	Avoid the environment with a great amount of metallic powder, oil mist, or erosive gases.
Operation humidity	<85%, RH(non-condensing or water drops)
Operation temperature	0°C ~ 40°C
Storage temperature	-20°C ~ 70°C
Weight(Net)	0.25kg
Dimensions	118X75.5X34mm
Ingress protection	IP20

Note: Please purchase related and complete communication cable.  
Type: Console wire (RS232-to-RJ45 crystal line)

## Interface Introduction

Interface		Function
X1	RS232	RS232 port
I/O DIP	SW1~SW7	ID DIP
X2	DIN1+	DIN1 positive
	DIN1-	DIN1 negative
	DIN2+	DIN2 positive
	DIN2-	DIN2 negative
	DIN3+	DIN3 positive
	DIN3-	DIN3 negative
	485/A 485/B	Differential 485 signal input

Note: (1) DIN1, DIN2 and DIN3 use high-speed opto-isolation, max input frequency is 50KHz, min pulse width is 10us  
(2) DIN3 uses low-speed opto-isolation, max input frequency is 1KHz



- 3 opto-isolation digital signal input channels, 3 channels support voltage range 5~24VDC;
- Support CW/CCW, PLS+DIR;
- Non-isolation CAN interfaces, support CANopen protocol;
- Multiple I/O functions, support homing, multi-speed, multi-position, etc;
- Support automatic parameter adjustable regulation, self-defined half-lock, step smooth filter;
- Over-voltage, under-voltage, overheat and over-current protection;
- Support RS232 communication, parameter settings by KincoStep software.

## Mechanical Dimensions (Unit:mm)

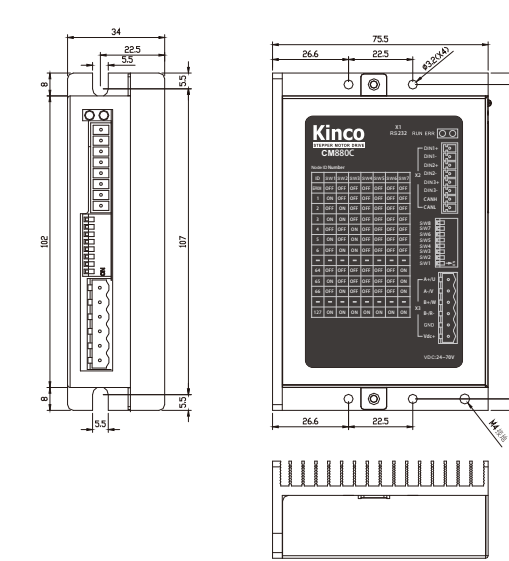

## Technical Specifications

Input voltage	24 ~ 70VDC
Over-voltage protection	85VDC
Under-voltage protection	15VDC
Phase current (Peak)	0.15 ~ 8A (Peak)
Subdivision	Set by KincoStep software
Adaptable motor	2&3 phase hybrid stepper motor
Control mode	I/O control; CANopen control; Pulse control: PLS+DIR, CW/CCW
Cooling method	Natural air cooling
Operation environment	Avoid the environment with a great amount of metallic powder, oil mist, or erosive gases.
Operation humidity	<85%, RH(non-condensing or water drops)
Operation temperature	0°C ~ 40°C
Storage temperature	-20°C ~ 70°C
Weight	0.25kg
Dimensions	118X75.5X34mm
Ingress protection	IP20

Note: Please purchase related and complete communication cable.  
Type: Console wire (RS232-to-RJ45 crystal line)

## Interface Introduction

Interface		Function
X1	RS232	RS232 port
I/O DIP	SW1~SW7	ID DIP
X2	DIN1+	DIN1 positive
	DIN1-	DIN1 negative
	DIN2+	DIN2 positive
	DIN2-	DIN2 negative
	DIN3+	DIN3 positive
	DIN3-	DIN3 negative
	485/A 485/B	Differential 485 signal input

Note: (1) DIN1, DIN2 and DIN3 use high-speed opto-isolation, max input frequency is 50KHz, min pulse width is 10us  
(2) DIN3 uses low-speed opto-isolation, max input frequency is 1KHz

# Stepper Driver 2CM0870



- 1. Support parameter self-adaptive function, generate optimal parameters according to motor type, ensure motor run at optimal performance;
- Phase memory function;
- Automatic half-current function, selected by DIP switches;
- Test running function, selected by DIP switches;
- Over voltage protection, over current protection functions;
- Micro-step filter function can smooth input pulse to reduce transient motion of motor, make sure motor run more smoothly;
- Opto-isolation signal input, pulse responding frequency up 200KHz;
- Opto-isolation 5-24V pulse input, responding frequency up 400KHz;
- 16 subdivision levels and 8 current levels are selectable by DIP switches;
- Pulse type is selectable by DIP switches: PUL+DIR&CW/CCW

## Mechanical Dimensions (Unit:mm)

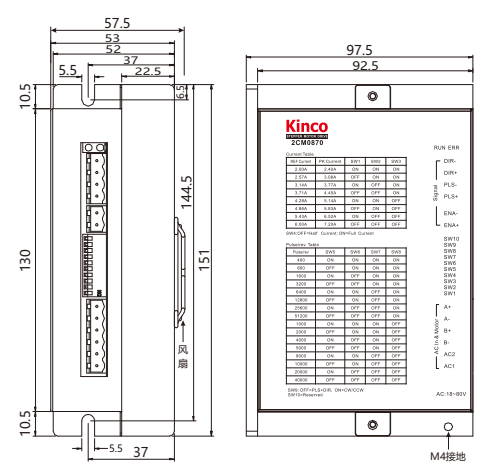

## Function of DIP switches

Function	DIP setting	Description
Micro-step smooth & dynamic filter disable	Sw5, SW6, SW10=ON; Others=OFF	Set DIP switches according to functions required when power off. Power on driver, RUN LED blinking is green, ERR LED is red. It means settings take effect, Then power off driver, reset subdivision and current for normal use.
Micro-step smooth filter enable	SW5, SW7, SW10=ON; Others=OFF	
Micro-step dynamic filter enable	SW5, SW8, SW10=ON; Others=OFF	
Test motor parameter upon power on disable	SW6, SW7, SW8, SW10=ON; Others=OFF	Test motor parameter upon power on enable
Test motor parameter upon power on enable	SW5, SW6, SW7, SW10=ON; Others=OFF	
Test running	SW6, SW8, SW10=ON; Others=OFF	Motor running @80RPM
Automatic half-current	SW4=ON or SW4=OFF	SW4=ON to enable automatic half-current. Phase current will reduce to half of the set value after motor stops for 1.5s.
Double pulse input	SW9=ON; Others=OFF	Set SW9=ON, subdivision, current, this mode can be use after power on
Single pulse input	SW9=OFF; Others=OFF	Set SW5=ON to enable automatic half-current. Phase current will reduce to half of the set value after motor stops for 1.5s

## Technical Specifications

Input voltage	18~80VAC
Overvoltage protection	110VAC
Undervoltage protection	15VAC
Overheat protection	85°C(Temperature of thermistor)
Adaptable motor	57 and 86 series 2-phase hybrid stepper motor
Input signal	PLS(CW), DIR(CCW), ENA signal; Input voltage: 5VDC, input current 5mA@5VDC Valid input signal: bigger than 4VDC, Invalid input signal: smaller than 1.5VDC PLS, DIR signal max input frequency: 200KHz, min pulse width: 2.5us
Control mode	Pulse control: PLS+DIR, CW/CCW
Operator indicator	Combination of RUN and ERR LED indicates different status Over voltage, under voltage, over current,
Protection	over heat
Cooling way	Fan cooling
Operation environment	Avoid environment with great amount of metallic powder, oil mist, or erosive gases
Operation humidity	<85%, RH(Non-condensing or water drops)
Operation temperature	0°C~40°C
Storage temperature	-20°C~70°C
Weight	0.696Kg
Dimension	151X97.5X57.5mm

Subdivision setting (Unit: PULSE/REV)			Current setting (Unit:A)					
SW5	SW6	SW7	Pulse/rev	SW1	SW2	SW3	RMS	Peak
ON	ON	ON	400	1000	ON	ON	2	2.4
OFF	ON	ON	800	2000	OFF	ON	2.57	3.08
ON	OFF	ON	1600	4000	ON	OFF	3.14	3.77
OFF	OFF	ON	3200	5000	OFF	OFF	3.71	4.45
ON	ON	OFF	6400	8000	ON	ON	4.28	5.14
OFF	ON	OFF	12800	10000	OFF	ON	4.86	5.83
ON	OFF	OFF	25600	20000	ON	OFF	5.43	6.52
OFF	OFF	OFF	51200	40000	OFF	OFF	6	7.2

# Stepper Driver 2M412



- The maximum supply voltage can reach 40V;
- The bipolar constant current drive mode is taken, with a maximum drive current up to 1.2A per phase, which can drive any 42 series two-phase bipolar hybrid stepper motors with a current less than 1.2A;
- The drive output phase current of a motor can be regulated through the DIP switch, to match motors of different specifications;
- A DIP switch is used to set the automatic half current function of motors in statically locked status, which can greatly reduce heat dissipation of the motors;
- A dedicated control chip is used, with a maximum of 256/200 subdivisions. The subdivision function can be set by the DIP switch, to ensure the best operation stability;
- Supporting offline function so that the output current of a motor can be cut off if necessary;
- Optical coupling devices are used for the isolation of the input circuit of the control signals to reduce interference of external noises.

## Mechanical Dimensions (Unit:mm)

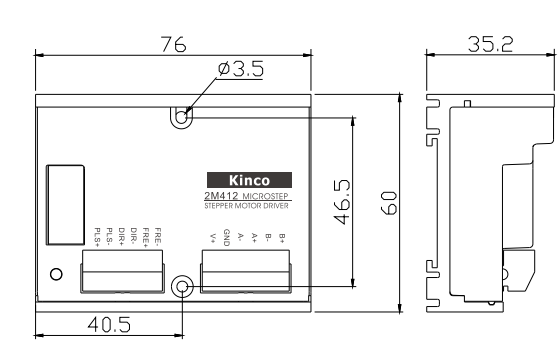

## Function of DIP switches

There is a red 8-bit function setting switch at the top of the driver, which is used to set the working mode and parameters of the driver. Please carefully read the reference before use. Do remember to cut off the power before changing the settings of the DIP switch.

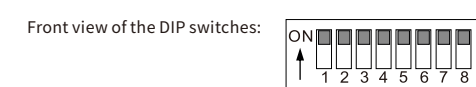

No.	ON	OFF	Remarks
DIP1~DIP4	Subdivision setting	Subdivision setting	
DIP5	Half current of static current	Full current of static current	
DIP6~DIP8	Output current setting	Output current setting	

The subdivision setting table			DIP1 is ON		DIP1 is OFF	
DIP2	DIP3	DIP4	subdivision	subdivision		
ON	ON	ON	N/A*	2		
OFF	ON	ON	4	4		
ON	OFF	ON	8	5		
OFF	OFF	ON	16	10		
ON	ON	OFF	32	25		
OFF	ON	OFF	64	50		
ON	OFF	OFF	128	100		
OFF	OFF	OFF	256	200		

\* N/A indicates invalid. The DIP switch is forbidden setting as N/A.

## Technical Specifications

Supply voltage	12 ~ 40V DC
Output phase current	0.2 ~ 1.2A
Control signal input current	6 ~ 16mA
Cooling method	Natural air cooling
Operating environment	Avoid the environment with a great amount of metallic powder, oil mist, or erosive gases
Operating temperature	-10°C ~ +45°C
Operating humidity	<85% (non-condensing or water drops)
Weight	0.13Kg

## Current setting

There is a red 8-bit function setting switch at the top of the driver, which is used to set the working mode and parameters of the driver. Please carefully read the reference before use. Do remember to cut off the power before changing the settings of the DIP switch.

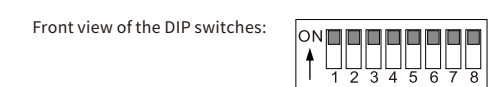

The output phase current setting table			
DIP6	DIP7	DIP8	Output Current
OFF	OFF	OFF	0.20A
OFF	OFF	ON	0.35A
OFF	ON	OFF	0.50A
OFF	ON	ON	0.65A
ON	OFF	OFF	0.80A
ON	OFF	ON	0.90A
ON	ON	OFF	1.00A
ON	ON	ON	1.20A

## Precaution!

It supports control signal voltage of 5VDC. When the voltage of control signal is 24VDC, then users should add a 2kohm resistor in the connection.



# Stepper Driver 2M1180N



- High performance, multiple functions, simple operation, cost-effective;
- Automatic parameter adjustable regulation, ensures motor run at optimal performance;
- Supporting driver test running function;
- Supporting phase memory function, driver will record phase position of motor during motor stop to ensure motor not shake when re-power;
- With step smooth filter, can smooth input pulse and reduce the transient motion of motor, make sure motor run more smoothly;
- Supporting automatic half current function of motors in statically locked status, which can greatly reduce heat dissipation of the motors;
- Automatic internal high-subdivision conversion technology ensures motor run at optimal subdivision state;
- Opto-isolation ERR signal output with max. current of 10mA;
- Opto-isolation signal input, with pulse response frequency up to 400KHz.

## Mechanical Dimensions (Unit:mm)

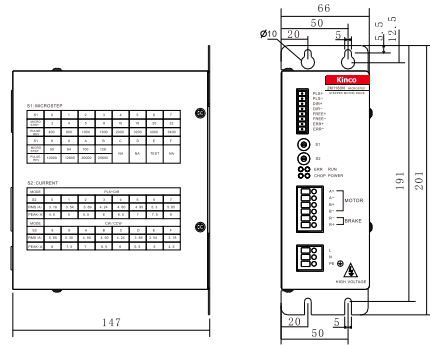

## Operation Table

Mode	S1	S2	Method
Auto Run	E	0~F	Set S1=E, S2=0~F when driver is powered off, then power on the driver, the motor will run at 60RPM automatically.
PLS+DIR	0~B	0~7	Set S1=0~B, S2=0~7 when driver is powered off, then power on the driver, the motor will run in PLS+DIR mode.
CW/CCW	0~B	8~F	Set S1=0~B, S2=8~F when driver is powered off, then power on the driver, the motor will run in CW/CCW mode.
Half current	F	C	Set S1 and S2 as the "MODE settings (as the left table)" when driver is powered off. Then power on the driver, the 4 LEDs will run as: RUN LED blinks, POWER LED is green, ERR LED is red, CHOP LED is off. It means the mode setting is succeed, then restart the driver, the driver will work in setting mode.
Full current	F	D	
Step smooth filter enable	F	F	
Step smooth filter disable	F	E	

## Technical Specifications

Input voltage	77~123VAC, (50Hz)	
Over-voltage protection	187VDC	
Under-voltage protection	85VDC	
Output current	4.5/5/5.5/6/6.5/7/7.5/8, 8 settable values in total. (Unit: A)	
Micro step	2/4/5/8/10/16/20/32/50/64/100/128, total 12 subdivisions.	
Adaptable motor	57/86/110 series 2-phase bipolar hybrid stepper motors	
Input signal	PLS(CW), DIR(CCW), A/B, FREE; Current range: 6~16mA	
Control mode	Pulse control: PLS+DIR, CW/CCW, A+B	
Output signal	ERR, open collector output, maximum current:10mA	
Automatic half current	The driver will reduce phase current of the motor by a half in 1.5 seconds	
Protection	Overvoltage, undervoltage, short circuit and over heat protection.	
Dynamic braking circuit *	Absorb regenerated energy of motor by connecting to power resistor. Custom function.	
Cooling way	Fan cooling	
Environment	Operation Environment	Avoid the environment with great amount of metallic powder, oil mist, or erosive gases.
	Operation humidity	<85%, RH (non-condensing or water drops)
	Operation temperature	0°C ~ +40°C
	Storage temperature	-20°C ~ +70°C
Weight	1.5Kg	
Dimensions	201 x 147 x 66 mm	
Ingress protection	IP20	

\* Please confirm with factory for custom of driver with dynamic braking circuit.

S1, Micro-step: switch for subdivision and test running function								
S1	0	1	2	3	4	5	6	7
Microstep	2	4	5	8	10	16	20	32
Pulse/rev	400	800	1000	1600	2000	3200	4000	6400
S1	8	9	A	B	C	D	E	F
Microstep	50	64	100	128				
Pulse/rev	10000	12800	20000	25600	NA	NA	TEST	NA

S2, Current: switch for current and PLS/DIR, CW/CCW setting								
Mode	PLS+DIR							
S2	0	1	2	3	4	5	6	7
Rms(A)	3.18	3.54	3.89	4.24	4.60	4.95	5.30	5.65
Peak(A)	4.5	5	5.5	6	6.5	7	7.5	8
Mode	CW/CCW							
S2	8	9	A	B	C	D	E	F
Rms(A)	5.65	5.30	4.95	4.60	4.24	3.89	3.54	3.18
Peak(A)	8	7.5	7	6.5	6	5.5	5	4.5

\* DIP switch is forbidden to set as N/A, or the driver will be alarm automatically.

# Stepper Driver 2M2280N



- High performance, multiple functions, simple operation, cost-effective;
- Automatic parameter adjustable regulation, ensures motor run at optimal performance;
- Supporting driver test running function;
- Supporting phase memory function, driver will record phase position of motor during motor stop to ensure motor not shake when re-power;
- With step smooth filter, can smooth input pulse and reduce the transient motion of motor, make sure motor run more smoothly;
- Supporting automatic half current function of motors in statically locked status, which can greatly reduce heat dissipation of the motors;
- Automatic internal high-subdivision conversion technology ensures motor run at optimal subdivision state;
- Opto-isolation ERR signal output with max. current of 10mA;
- Opto-isolation signal input, with pulse response frequency up to 400KHz.

## Mechanical Dimensions (Unit:mm)

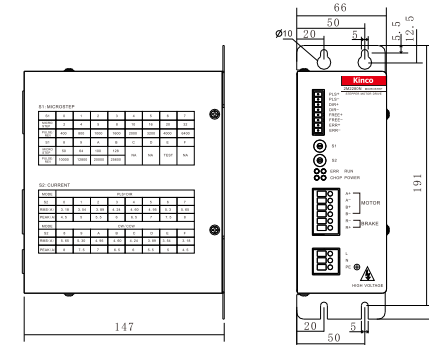

## Operation Table

Mode	S1	S2	Method
Auto Run	E	0~F	Set S1=E, S2=0~F when driver is powered off, then power on the driver, the motor will run at 60RPM automatically.
PLS+DIR	0~B	0~7	Set S1=0~B, S2=0~7 when driver is powered off, then power on the driver, the motor will run in PLS+DIR mode.
CW/CCW	0~B	8~F	Set S1=0~B, S2=8~F when driver is powered off, then power on the driver, the motor will run in CW/CCW mode.
Half current	F	C	Set S1 and S2 as the "MODE settings (as the left table)" when driver is powered off. Then power on the driver, the 4 LEDs will run as: RUN LED blinks, POWER LED is green, ERR LED is red, CHOP LED is off. It means the mode setting is succeed, then restart the driver, the driver will work in setting mode.
Full current	F	D	
Step smooth filter enable	F	F	
Step smooth filter disable	F	E	

## Technical Specifications

Input voltage	220VAC ±15%(50Hz) (187~253VAC)	
Over-voltage protection	395VDC	
Under-voltage protection	200VDC	
Output current	4.5/5/5.5/6A/6.5/7/7.5/8, 8 settable values in total. (Unit: A)	
Micro step	2/4/5/8/10/16/20/32/50/64/100/128, total 12 subdivisions.	
Adaptable motor	110/130 series 2-phase bipolar hybrid stepper motors	
Input signal	PLS(CW), DIR(CCW), A/B, FREE; Current range: 6~16mA	
Control mode	Pulse control: PLS+DIR, CW/CCW, A+B	
Output signal	ERR, open collector output, maximum current:10mA	
Automatic half current	The driver will reduce phase current of the motor by a half in 1.5 seconds	
Protection	Overvoltage, undervoltage, short circuit and over heat protection.	
Dynamic braking circuit *	Absorb regenerated energy of motor by connecting to power resistor. Custom function.	
Cooling way	Fan cooling	
Environment	Operation Environment	Avoid the environment with great amount of metallic powder, oil mist, or erosive gases.
	Operation humidity	<85%, RH (non-condensing or water drops)
	Operation temperature	0°C ~ +40°C
	Storage temperature	-20°C ~ +70°C
Weight	1.5Kg	
Dimensions	201 x 147 x 66 mm	
Ingress protection	IP20	

\* Please confirm with factory for custom of driver with dynamic braking circuit.

S1, Micro-step: switch for subdivision and test running function								
S1	0	1	2	3	4	5	6	7
Microstep	2	4	5	8	10	16	20	32
Pulse/rev	400	800	1000	1600	2000	3200	4000	6400
S1	8	9	A	B	C	D	E	F
Microstep	50	64	100	128				
Pulse/rev	10000	12800	20000	25600	NA	NA	TEST	NA

S2, Current: switch for current and PLS/DIR, CW/CCW setting								
Mode	PLS+DIR							
S2	0	1	2	3	4	5	6	7
Rms(A)	3.18	3.54	3.89	4.24	4.60	4.95	5.30	5.65
Peak(A)	4.5	5	5.5	6	6.5	7	7.5	8
Mode	CW/CCW							
S2	8	9	A	B	C	D	E	F
Rms(A)	5.65	5.30	4.95	4.60	4.24	3.89	3.54	3.18
Peak(A)	8	7.5	7	6.5	6	5.5	5	4.5

\* DIP switch is forbidden to set as N/A, or the driver will be alarm automatically.



# Stepper Driver 2H1160



- Power supply: 60VAC~123VAC;
- Bipolar constant current drive mode is adopted, with phase current up to 6.5A. 86 & 110 series bipolar hybrid stepper motors are adaptable;
- Dedicated control chip is adopted, full-step or half-step mode are selectable by DIP switches, suitable for application requiring high speed and high torque;
- Output phase current is selectable by DIP switches to match motors of different specifications;
- Automatic half-current is settable by DIP switches when motor is standstill locked, which could greatly reduce of motors;
- Support offline function to cut of current output if necessary;
- Opto couplers are used for the control signal circuit to reduce external interference.

## Mechanical Dimensions (Unit:mm)

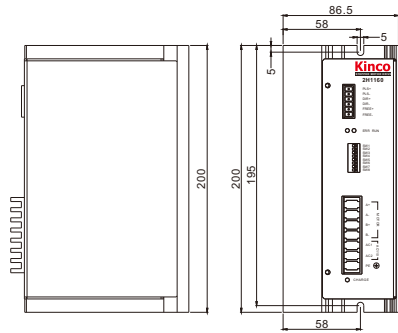

## Technical Specifications

Power supply	Single phase 60VAC~123VAC(50Hz)
Output phase current	2.5~6.5A
Input current of control signal	6~16mA
Cooling method	Nature air cooling
Operation environment	Avoid environment with great amount of metallic powder, oil mist, or erosive gases
Environment humidity	<85%, RH(Non-condensing or water drops)
Environment temperature	-10°C~+45°C
Weight(Net)	1.77kg

## Function of DIP switches

Front view of the DIP switches:

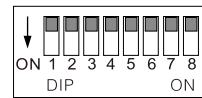

No.	ON	OFF	Remarks
DIP1~DIP5	Set current	Set current	
DIP6	Half-current valid	Half-current invalid	
DIP7	Half-step 400 steps/round	Full-step 200 steps/round	

## Precaution!

Control signal range is 5~24VDC. No need to add 2Kohm resistor when control signal is 24VDC.

# Stepper Driver 3M2280N



- High performance, diverse functions, simple operation, cost-effective;
- Automatic parameter adjustable regulation;
- Driver test running function;
- Phase memory function;
- PLS+DIR and CW/CCW control signal available;
- Opto-isolation ERR signal output;
- The driver will reduce the phase current of the motor by a half in 1.5 seconds;
- Opto-isolation signal input, with pulse response frequency up to 400 KHz;
- 14 micro-step value, the maximum micro-step value is 20000 pulse/rev.The maximum output phase current is 8A(Peak);
- With the protection function of over-voltage, under-voltage, over-current, overheat and phase dislocation;
- With step smooth filter, can smooth the input pulse, reduce the transient motion of motor, make the motor runs more smoothly.

## Mechanical Dimensions (Unit:mm)

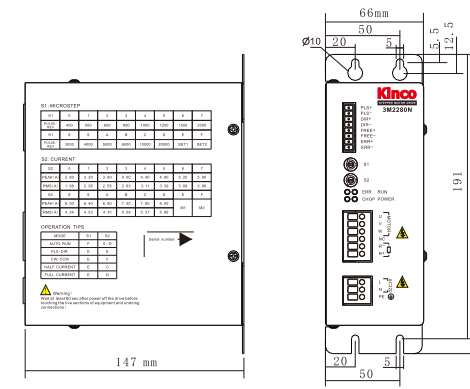

## Technical Specifications

Input voltage	220V AC±15% (50Hz)	
Over-voltage protection	395VDC	
Under-voltage protection	200VDC	
Overheat protection	80°C(Temperature of thermistor)	
Phase current	2.8/3.2/3.6/4.0/4.4/4.8/5.2/5.6/6.0/6.4/6.8/7.2/7.6/8.0, 14 settable values in total. (Unit: A)	
Micro step	400~30000 pulse/rev, total 14 subdivisions	
Adaptable motor	110 / 130 series 3-phase hybrid stepper motor	
Input signal	PLS(CW) / DIR(CCW) / FREE; current range: 6~16mA	
Control signal mode	PLS+DIR; CW/CCW, A+B	
Output signal	ERR, open collector output, max current: 10mA	
Automatic half-current	The driver will reduce the phase current of the motor by a half in 1.5 seconds	
Protection	Over-voltage, under-voltage, short circuit, and over heat protection	
Dynamic braking circuit*	Absorb regenerated energy of motor by connecting to power resistor. Custom function	
Cooling method	Forced air cooling	
Environment	Operation environment	Avoid the environment with great amount of metallic powder, oil mist, or erosive gases
	Operation humidity	<85%, RH (non-condensing or water drops)
	Operation temperature	0°C ~ +40°C
	Storage temperature	-20°C ~ +70°C
Weight (net)	1.5Kg	
Dimensions	201 x 147 x 66 mm	
Ingress protection	IP20	

## Current setting

Front view of the DIP switches:

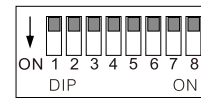

Settings of output phase current					
DIP1	DIP2	DIP3	DIP4	DIP5	Peak value of output current
ON	ON	ON	ON	ON	2.5A
OFF	ON	ON	ON	ON	3.0A
ON	OFF	ON	ON	ON	3.5A
OFF	OFF	ON	ON	ON	4.0A
ON	OFF	OFF	ON	ON	4.5A
OFF	OFF	OFF	ON	ON	5.0A
OFF	OFF	OFF	OFF	ON	6.0A
OFF	OFF	OFF	OFF	OFF	6.5A

## Operation Table

Mode	S1	S2	Method
Auto Run	F	0~D	Set the s1&s2 as S1=F,S2=0~D when driver is power off, then power on the driver, the motor will run automatically.
PLS+DIR	E	E	Set S1 and S2 as the "MODE settings ( as the left table)" when driver is power off, then power on the driver, the 4 standards LED will run as: , this means the mode setting is success, then reboot the driver, the driver will work in setting mode.
CW/CCW	E	F	
HALF CURRENT	E	C	
FULL CURRENT	E	D	
Step smooth filter enable	F	F	Enable smoothing acceleration/ deceleration function.
Step smooth filter disable	F	E	Enable immediately response mode.

### S1, Micro-step:switch for subdivision and test running function

S1	0	1	2	3	4	5	6	7
Pulse/rev	400	500	600	800	1000	1200	1500	2000
S1	8	9	A	B	C	D	E	F
Pulse/rev	3000	4000	5000	6000	10000	20000	SET1	SET2

### S2, Current:switch for current and PLS/DIR, CW/CCW setting

S2	0	1	2	3	4	5	6	7
Peak(A)	2.80	3.20	3.60	4.00	4.40	4.80	5.20	5.60
Rms(A)	1.98	2.26	2.55	2.83	3.11	3.39	3.68	3.96
S2	8	9	A	B	C	D	E	F
Peak(A)	6.00	6.40	6.80	7.20	7.60	8.00	M1	M2
Rms(A)	4.24	4.53	4.81	5.09	5.37	5.66		

# Bus Stepper Driver FM860

# Bus Stepper Driver FM860



- 6 opto-isolation digital input channels, 3 channels support voltage range 5~24VDC;
- 3 opto-isolation digital signal output channels, max current 100mA;
- 1 analog signal input channel(±10V) speed control;
- Support PLS+DIR, CW/CCW and A+B signal;
- Opto-isolation CAN or RS485 interfaces;
- Support CANopen and Modbus protocol;
- Multiple I/O functions, support homing, multi-speed;
- Support automatic parameter adjustable regulation, self-defined shalf-load, step smooth filter;
- Over-voltage, under-voltage, overheat and over-current protection;
- Support RS232 communication, parameter settings by KincoStep software;
- CE and RoHS.

## Mechanical Dimensions (Unit:mm)

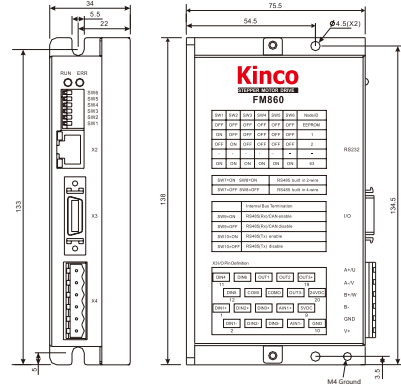

## Technical Specifications

Model	FM860-AA-000 (Supports CANopen) FM860-LA-000 (Support RS485 Modbus)
Input voltage	24 ~ 70VDC
Over-voltage protection	85V
Under-voltage protection	15V
Phase current (Peak)	0.15 ~ 8A
Subdivision	Set by "KincoStep" software
Adaptable motor	42/57/86 series 2-phase or 57/85 series 3-phase hybrid stepper motor
Control mode	CANopen or Modbus control; I/O control; Analog input Pulse control: PLS+DIR, CW/CCW, A+B
Cooling method	Natural air cooling
Operation environment	Avoid the environment with a great amount of metallic powder, oil mist, or erosive gases.
Operation humidity	<85%, RH(non-condensing or water drops)
Operation temperature	0°C ~ +40°C
Storage temperature	-20°C ~ +70°C
Weight	0.36Kg
Dimensions	134.5x 75.5 x 34mm
Ingress protection	IP20

Note: The communication cable is suggested to be purchased with the first order.  
Model: Console configuration cable (conversion cable RS232-to-RJ45)

## Interface Introduction

Interface	Symbol	Function
DIP switch	SW9~SW10	Switches for terminal resistor setting
	SW7~SW8	Switches for setting 2-wire or 4-wire RS485
	SW1~SW6	ID DIP

Interface No.	Interface name	Interface type	Pin No.	Symbol	Signal name	Interface No.	Interface name	Interface	Pin No.	Symbol	Signal name
X1A/X1B	RS485 interface input/output	RJ45 network port female	1	RX+	Data receive +	X1A/X1B	CAN interface input/output	RJ45 network port female	1	CAN_H	Signal +
			2	RX-	Data receive -				2	CAN_L	Signal -
			3	NC					3	GNDB	GND
			4	TX-	Data send +				4	NC	
			5	TX+	Data send -				5	NC	
			6	NC					6	NC	
			7	NC					7	NC	
			8	GNDB	GND				8	NC	

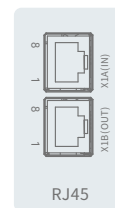

Interface No.	Interface name	Interface type	Pin No.	Symbol	Signal name	Function
X2	RS232 interface	Rj45 network port female	1	NC		Connect to PC, set parameters or monitor state by kincoservo+
			2	NC		
			3	TX	Driver's data send	
			4	GND	GND	
			5	NC		
			6	RX	Driver's data receive	
			7	NC		
			8	NC		

## Interface Introduction (FM560&FM880)

Interface No.	Pin No.	Symbol	Signal name	Function
X3	1	DIN1+	DIN1 positive	High speed digital signal input interface Input voltage: 5~24VDC Input current: 8mA@5VDC, 12mA@24VDC Valid input signal: >3VDC Invalid input signal: <-1VDC
	2	DIN1-	DIN1 negative	
	3	DIN2+	DIN2 positive	
	4	DIN2-	DIN2 negative	
	5	DIN3+	DIN3 positive	
	6	DIN3-	DIN3 negative	
	11	DIN4	DIN4 input	Low speed digital signal input interface Input voltage: 12~24VDC Input current: 4mA@12VDC, 8mA@24VDC Valid input signal: >8VDC Invalid input signal: <-5VDC
	12	DIN5	DIN5 input	
	13	DIN6	DIN6 input	
	14	COM1	Common port of DIN4, DIN5, DIN6	
	7	AIN1+	AIN1 differential signal positive	The analog signal input interface: The input impedance: 180K Max. input frequency: 4kHz Max. Withstand voltage: 24VDC
	8	AIN1-	AIN1 differential signal negative	
	10	GND	Common port of AIN1 and logic power supply	
	9	5VDC	5VDC Logic power output	The maximum output current: 200mA
	20	24VDC	24VDC Logic power input	Auxiliary logic power supply when external power supply does not work
	15	OUT1	OUT1 output	Max. output current: 100mA Max. Withstand voltage: 30VDC Max. Voltage drop: 0.8VDC@100mA
	17	OUT2	OUT2 output	
	16	COMO	Common port if OUT1 and OUT2	
19	OUT3+	OUT3 positive		
18	OUT3-	OUT3 negative		

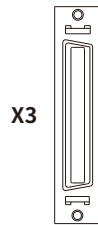

Note: (1) DIN1, DIN2 and DIN3 use high-speed opto-isolation, max input frequency is 400KHz, min pulse width is 1.3us  
(2) DIN4~DIN6 use low-speed opto-isolation, max input frequency is 1KHz  
(3) OUT uses low-speed opto-isolation. max output frequency is 1KHz

Interface	Name	Type	Pin	Symbol	Signal name	Function
X4	Power wiring terminal	6 bits 5mm gap Plug -in@plug-out terminal	1	A+/U	Motor cable interface	Two-phase or three-phase motor interface
			2	A-/V		
			3	B+/W		
			4	B-	Power supply interface	
			5	GND		
			6	Vdc+		

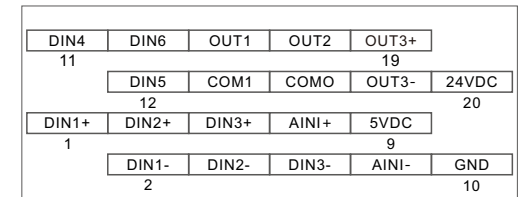

## Interface Introduction (FM880)

Interface No.	Pin No.	Symbol	Signal name	Function
X3	1	DIN1+	DIN1 positive	High speed digital signal input interface Input voltage: 5~24VDC Input current: 8mA@5VDC, 12mA@24VDC Valid input signal: >3VDC Invalid input signal: <-1VDC
	2	DIN1-	DIN1 negative	
	3	DIN2+	DIN2 positive	
	4	DIN2-	DIN2 negative	
	5	DIN3+	DIN3 positive	
	6	DIN3-	DIN3 negative	
	11	DIN4	DIN4 input	Low speed digital signal input interface Input voltage: 12~24VDC Input current: 4mA@12VDC, 8mA@24VDC Valid input signal: >8VDC Invalid input signal: <-5VDC
	12	DIN5	DIN5 input	
	13	DIN6	DIN6 input	
	14	COM1	Common port of DIN4, DIN5, DIN6	
	7	AIN1+	AIN1 differential signal positive	The analog signal input interface: The input impedance: 180K Max. input frequency: 4kHz Max. Withstand voltage: 24VDC
	8	AIN1-	AIN1 differential signal negative	
	10	GND	Common port of AIN1 and logic power supply	
	9	5VDC	5VDC Logic power output	The maximum output current: 200mA
	20	24VDC	24VDC Logic power input	Auxiliary logic power supply when external power supply does not work
	15	OUT1	OUT1 output	Max. output current: 100mA Max. Withstand voltage: 30VDC Max. Voltage drop: 0.8VDC@100mA
	17	OUT2	OUT2 output	
	16	COMO	Common port if OUT1 and OUT2	
19	OUT3+	OUT3 positive		
18	OUT3-	OUT3 negative		



Note: (1)DIN1, DIN2 and DIN3 use high-speed opto-isolation, max input frequency is 400KHz, min pulse width is 1.3us  
(2)DIN4~DIN6 use low-speed opto-isolation, max input frequency is 1KHz  
(3)OUT uses low-speed opto-isolation. max output frequency is 1KHz

Interface	Name	Type	Pin	Symbol	Signal name	Function
X4	Power wiring terminal	6 bits 5mm gap Plug-in@plug-out terminal	1	A+/U	Motor cable interface	Two-phase or three-phase motor interface
			2	A-/V		
			3	B+/W		
			4	B-	Power supply interface	
			5	GND		
			6	Vdc+		

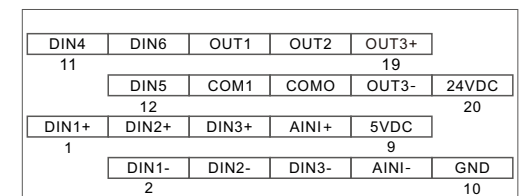

# Bus stepper driver FM560&FM880



- 6 channels of optocoupler digital signal input, three of which support wide voltage input (5 ~ 24VDC);
- 3 light coupling digital signals lost output;
- all the analog input (plus or minus 10 v) control speed;
- support double pulse (the CW/CCW) model (P/D), pulse direction and incremental encoder (AB) mode control;
- 100Mbps Ethernet transceiver with isolation;
- support EtherCAT bus protocol control, optimize customer control circuit;
- has rich IO function configuration, support origin and multistage speed control mode;
- support motor parameters automatically to adapt to, custom lock shaft current, such as micro step filtering function;
- powerful protection function: overvoltage, undervoltage, overheating and over-current protection.
- RS232 serial communication, the use of upper machine software KincoStep parameters set;

## Mechanical Dimensions (Unit:mm)

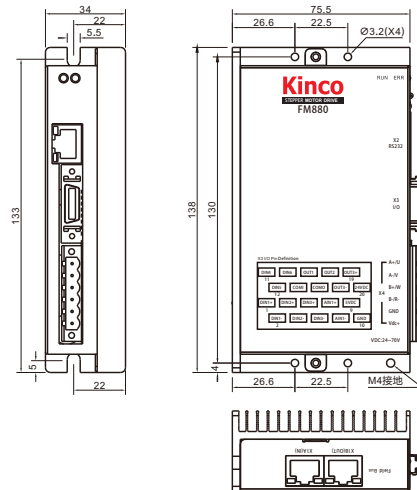

## Technical Specifications

Model	FM560-EA-000	FM880-EA-000
Supply voltage	24VDC~50VDC	24VDC~70VDC
Over-voltage protection	Above 85VDC	Above 85VDC
Under-voltage protection	Below 15VDC	Below 15VDC
Input current	0.1~6A (Peak)	0.1~10A (Peak)
Subdivision	Upper computer software KincoStep setting	
Adaptive motor	Two - phase type 42, 57 hybrid stepping motor	Two - phase 86 and three - phase 57, 85 hybrid stepping motors
Control Method	EtherCAT bus protocol control, IO control, analog control Pulse control: pulse + direction (PLS+DIR, positive and negative pulse (CW/CCW), A+B phase)	
Cooling method	Natural air cooling	
Operating environment	Avoid large amounts of metal dust, oil mist or corrosive gases	
Operating humidity	<85%, RH (No dews or dewdrops)	
Operating temperature	0°C~+40°C	
Storage temperature	-20°C~+70°C	
Weight	0.363Kg	
Dimensions	134.5x 75.5 x 34mm	
Ingress protection	IP20	

Remarks:  
It is recommended to purchase the matching communication cable together when purchasing for the first time. Model: Console configuration line (RS232 serial port to RJ45 crystal line)

## Interface Introduction

Interface No.	Interface name	Interface type	Pin No.	Symbol	Signal name
X1A/X1B	EtherCAT communication interface input	RJ45 network female port	1	TD+	Sending the signal forward
			2	TD-	Negative end of sending signal
			3	RD+	Positive end of receiving signal
			4	NC	
			5	NC	
			6	RD-	Negative end of receiving signal
			7	NC	
			8	NC	

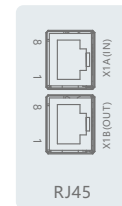

Interface No.	Interface name	Interface type	Pin No.	Symbol	Signal name	Function
X2	RS232 interface	RJ45 network port female	1	NC		Connect to PC, set parameters or monitor state by kincoservo+
			2	NC		
			3	TX	Driver's data send	
			4	GND	GND	
			5	NC		
			6	RX	Driver's data receive	
			7	NC		
			8	NC		

# Two-phase stepper motor/42 series

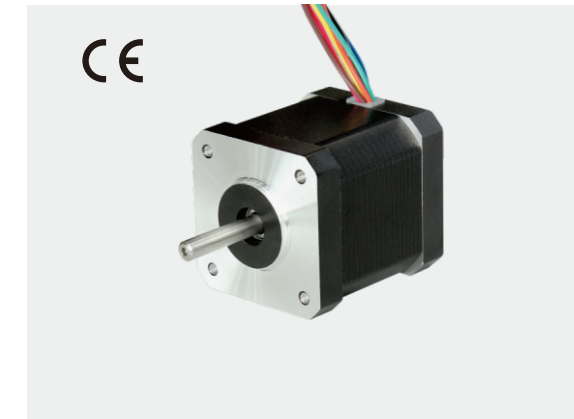

## Dimensions (Unit : mm)

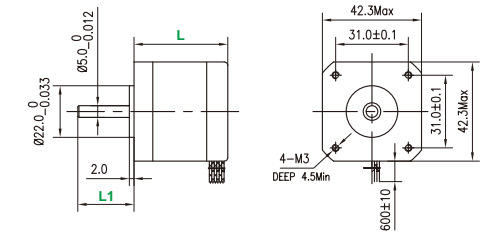

Model	L	L1
2S42Q-0348	48	24±0.5
2S42Q-0240	40	16±0.5

## Specification

Technical Specifications	2S42Q-0348	2S42Q-0240
Step angle	1.8°	1.8°
Phase current (A)	Series	0.7
	Parallel	1.4
Holding torque (Nm)	0.34	0.22
Damping torque (Nm)	0.026	0.022
Winding resistance (Ω)	4.6 ± 10%	12.5 ± 10%
Winding inductance (mH)	4.0 ± 20%	21 ± 20%
Motor inertia (kg.cm <sup>2</sup> )	0.068	0.054
Motor length L (mm)	48	40
Shaft diameter (mm)	5	5
Number of lead wires	8	4
Insulation class	B	
Withstand voltage level	500VAC for 1minute	
Max. axial load (N)	10N	
Max. radial load (N)	28N (20mm from the flange)	
Operating temperature	-20°C~+50°C	
Surface temperature rise	Max.80°C (Both phases connected with rated current)	
Insulation impedance	Minimum 100MΩ, 500V DC	
Weight (kg)	0.36	0.28
No-load start frequency	14K	14K
Ingress protection	IP40	

## Motor cable

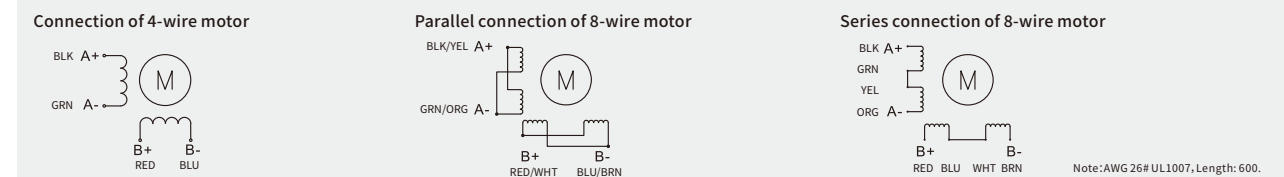

## Torque-frequency curve

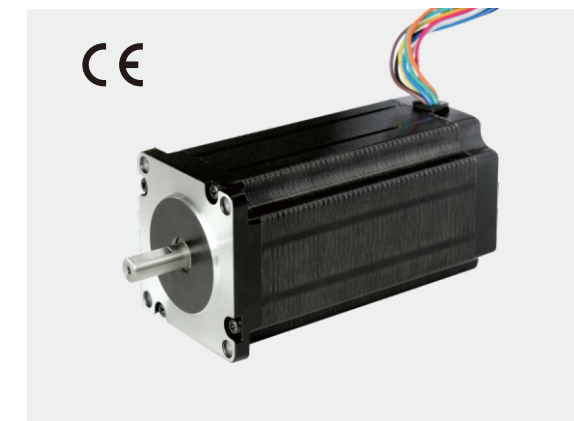
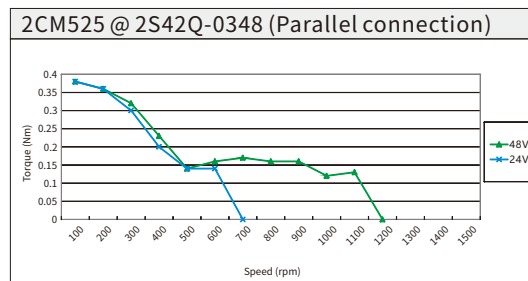
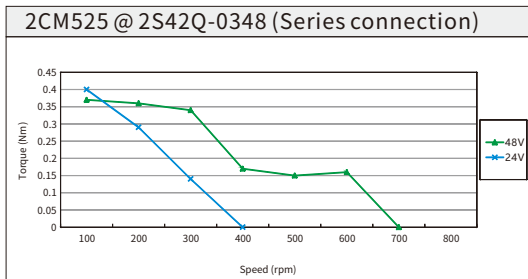
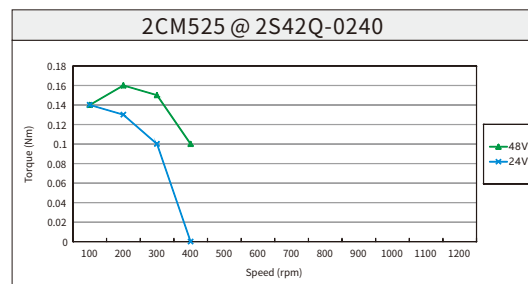

## Dimensions (Unit : mm)

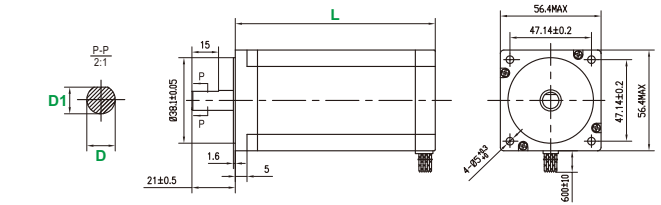

Model	L	D	D1
2S57Q-25B2	112	Ø8.0	7.5±0.1
2S57Q-2280	80	Ø8.0	7.5±0.1
2S57Q-1376	76	Ø6.35	5.8±0.1
2S57Q-0956	56	Ø6.35	5.8±0.1
2S57Q-0541	41	Ø6.35	5.8±0.1

## Specification

Technical Specifications	2S57Q-25B2	2S57Q-2280	2S57Q-1376	2S57Q-0956	2S57Q-0541	
Step angle	1.8°	1.8°	1.8°	1.8°	1.8°	
Phase current (A)	Series	2.9	2.8	1.96	1.96	0.70
	Parallel	6	5.6	3.92	3.92	1.50
Holding torque (Nm)	2.5	2.2	1.3	0.9	0.5	
Damping torque (Nm)	0.12	0.07	0.068	0.04	0.022	
Winding resistance (Ω)	1±10%	0.8±10%	1±10%	0.8±10%	3.6±10%	
Winding inductance (mH)	1.8±20%	1.8±20%	2.1±20%	1.2±20%	4.1±20%	
Motor inertia (kg.cm <sup>2</sup> )	0.8	0.53	0.48	0.3	0.135	
Motor length L (mm)	112	80	76	56	41	
Shaft diameter (mm)	8	8	6.35	6.35	6.35	
Number of lead wires	8					
Insulation class	B					
Withstand voltage level	500VAC for 1minute					
Max. axial load (N)	15N					
Max. radial load (N)	75N (20mm from the flange)					
Operating temperature	-20°C~+50°C					
Surface temperature rise	Max.80°C (Both phases connected with rated current)					
Insulation impedance	Minimum 100MΩ, 500V DC					
Weight (kg)	1.7	1.1	1	0.7	0.45	
No-load start frequency	12K	12K	14K	12K	12K	
Ingress protection	IP40					

## Motor cable

Parallel connection of 8-wire motor

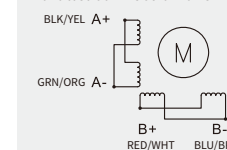

Series connection of 8-wire motor

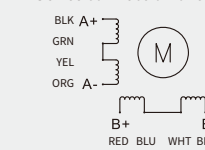

Note:AWG 22# UL1007, Length: 600.



# Two-phase stepper motor/57 series

## Torque-frequency curve

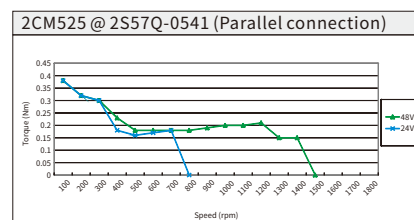
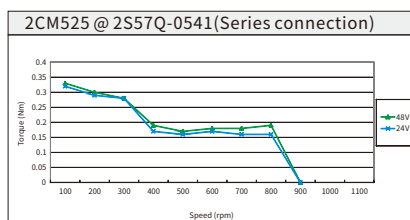
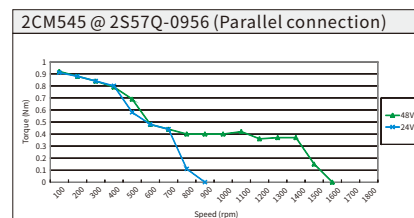
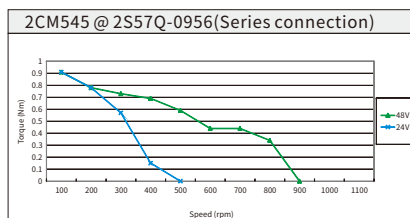
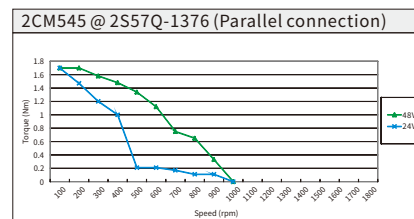
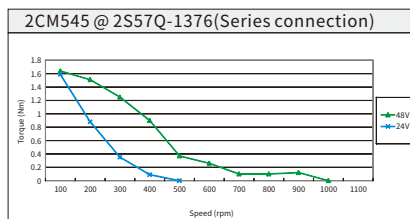
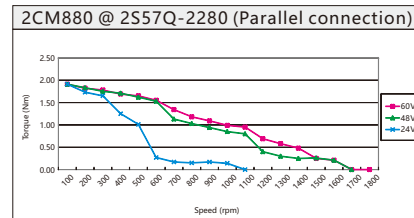
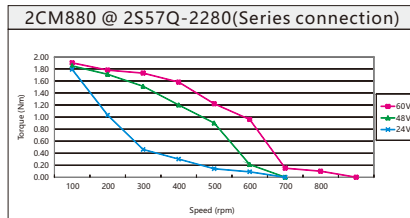
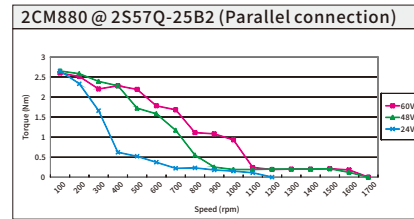
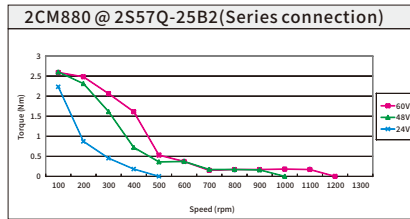

# Two-phase stepper motor/86 series

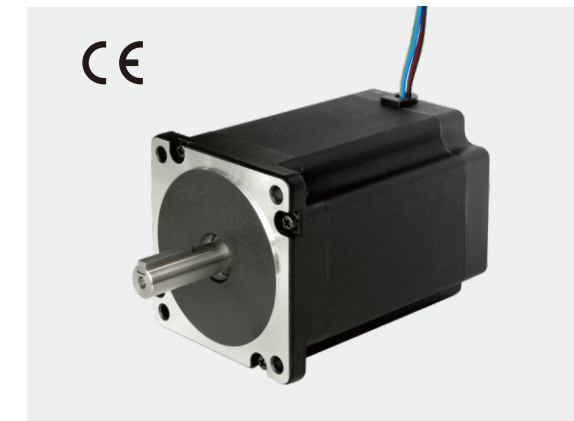

## Dimensions (Unit:mm)

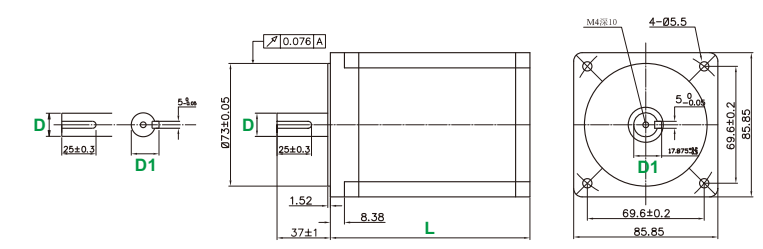

Model	L	D	D1
2S86Q-051F6	156	Ø15.875	17.875 <sup>+0.2</sup> <sub>-0.3</sub>
2S86Q-85B8	118	Ø13	15 <sup>+0.2</sup> <sub>-0.3</sub>
2S86Q-4580	80	Ø13	15 <sup>+0.2</sup> <sub>-0.3</sub>
2S86Q-3465	65	Ø13	15 <sup>+0.2</sup> <sub>-0.3</sub>

## Specification

Technical Specifications	2S86Q-051F6	2S86Q-85B8	2S86Q-4580	2S86Q-3465
Step angle	1.8°	1.8°	1.8°	1.8°
Phase current (A)	6.0	6.0	6.0	6.0
Holding torque (Nm)	12.8	8.5	4.5	3.4
Damping torque (Nm)	0.36	0.24	0.12	0.08
Winding resistance (Ω)	0.85 ± 10%	0.6 ± 10%	0.38 ± 10%	0.3 ± 10%
Winding inductance (mH)	10 ± 20%	6 ± 20%	3.5 ± 20%	1.7 ± 20%
Motor inertia (kg.cm <sup>2</sup> )	4	3.4	1.4	1
Motor length L (mm)	156	118	80	65
Shaft diameter (mm)	15.875	13	13	13
Number of lead wires	4			
Insulation class	B			
Withstand voltage level	1200VAC 1S 5mA			
Max. axial load (N)	60			
Max. radial load (N)	220			
Operating temperature	-20°C ~ +50°C			
Surface temperature rise	Max. 80°C (Both phases connected with rated current)			
Insulation impedance	Minimum 100MΩ, 500V DC			
Weight (kg)	5.3	3.7	2.3	1.7
Startup freq. with no load(Hz)*	5.8K	10K	9.1K	10K
Ingress protection	IP40			

Note: The startup freq. is tested under condition of 2000 steps/round, only for reference.

## Motor cable

Two-phase 4-wire motor

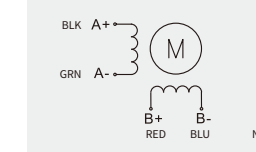

Note: AWG 18 # UL1332, Length: 600.

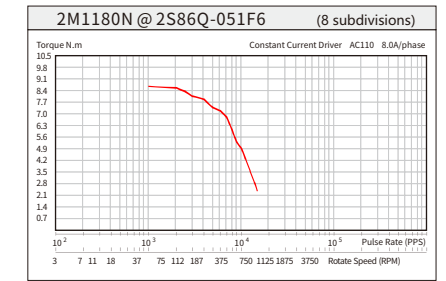

## Torque-frequency curve

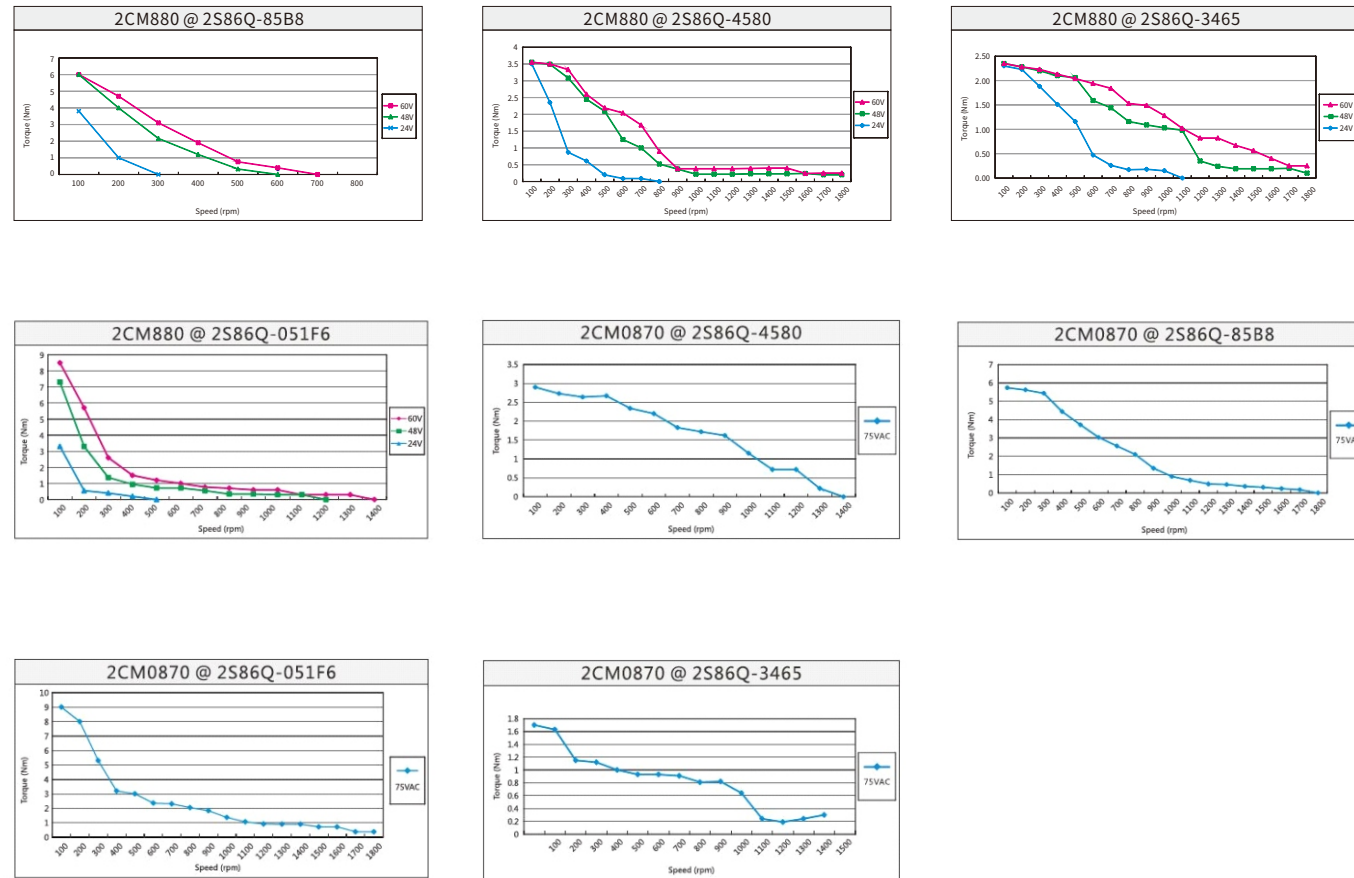

## Dimensions (Unit:mm)

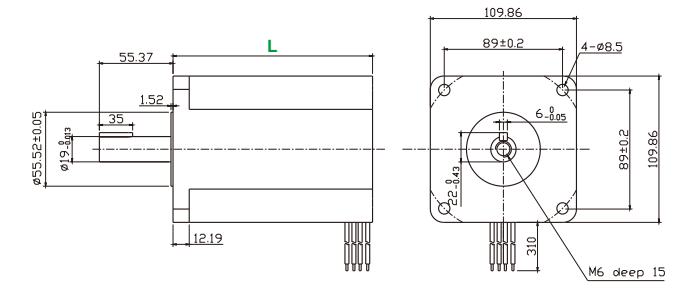
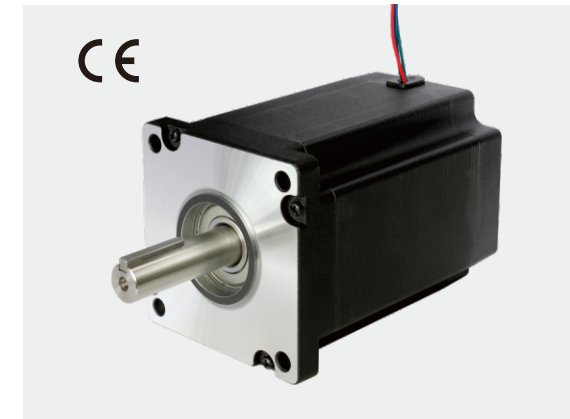

## Specification

Technical Specifications	2S110Q-054K1	2S110Q-047F0	2S110Q-03999
Step angle	1.8°	1.8°	1.8°
Phase current (A)	8.0	6.5	5.5
Holding torque (Nm)	30	21	11.7
Damping torque (Nm)	0.75	0.59	0.3
Winding resistance (Ω)	0.67 ± 10%	0.72 ± 10%	0.7 ± 10%
Winding inductance (mH)	11 ± 20%	12.8 ± 20%	9.8 ± 20%
Motor inertia (kg.cm <sup>2</sup> )	16.2	10.9	5.5
Motor length L (mm)	201	150	99
Shaft diameter (mm)	19	19	19
Number of lead wires	4		
Insulation class	B		
Withstand voltage level	1200VAC 1S 5mA		
Max. axial load (N)	60		
Max. radial load (N)	220		
Operating temperature	-20°C ~ +50°C		
Surface temperature rise	Max. 80°C (Both phases connected with rated current)		
Insulation impedance	Minimum 100MΩ, 500V DC		
Weight (kg)	11.7	8.4	5.0
Startup freq. with no load(Hz)*	4.8K	4.5K	5.2K
Ingress protection	IP40		

Note: The startup freq. is tested under condition of 2000 steps/round, only for reference.

## Motor cable

Two-phase 4-wire motor

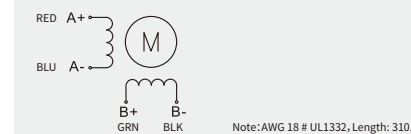

## Torque-frequency curve

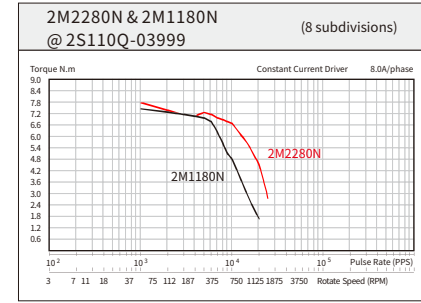
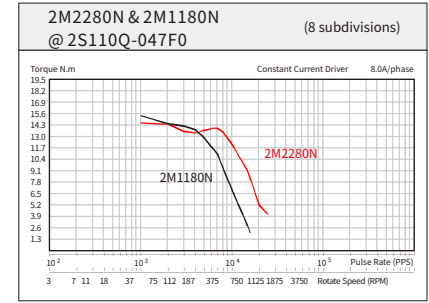
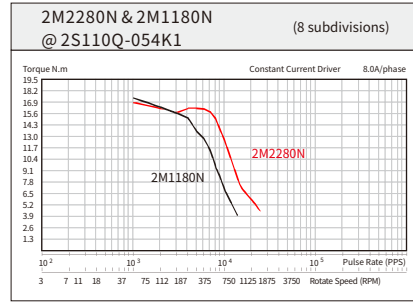
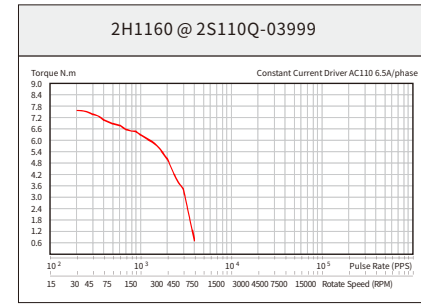
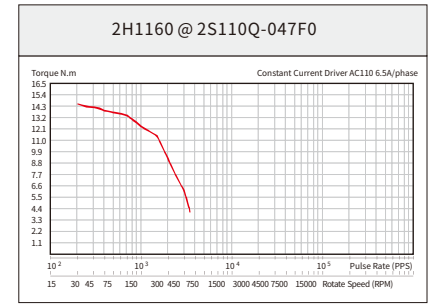
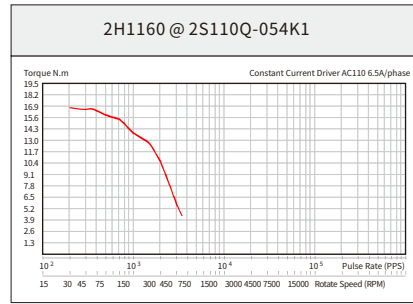

## Dimensions (Unit:mm)

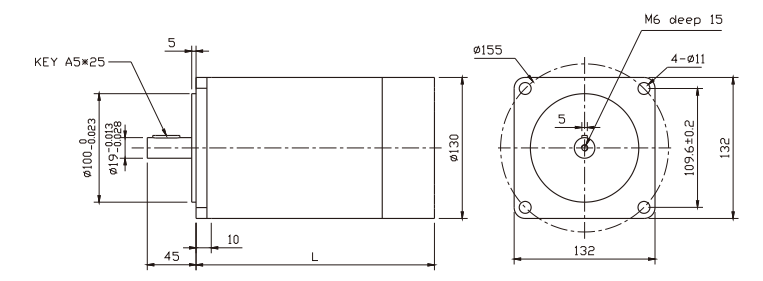

## Specification

Technical Specifications	2S130Y-063R8	2S130Y-039M0
Step angle	1.8°	1.8°
Phase current (A)	7.0	6.0
Holding torque (Nm)	40.0	27.0
Damping torque (Nm)	1.2	0.8
Winding resistance (Ω)	0.9 ± 10%	0.65 ± 10%
Winding inductance (mH)	9.5 ± 20%	13.8 ± 20%
Motor inertia (kg.cm <sup>2</sup> )	48.4	33.3
Motor length L (mm)	230	165
Shaft diameter (mm)	19	19
Number of lead wires	4	
Insulation class	B	
Withstand voltage level	1800VAC 1S 5mA	
Max. axial load (N)	60	
Max. radial load (N)	220	
Operating temperature	-20°C ~ +50°C	
Surface temperature rise	Max. 80°C (Both phases connected with rated current)	
Insulation impedance	Minimum 100MΩ, 500V DC	
Weight (kg)	19.0	13.0
Startup freq. with no load(Hz)*	4.1K	4.9K
Ingress protection	IP40	

Note: The startup freq. is tested under condition of 2000 steps/round, only for reference.

## Motor cable

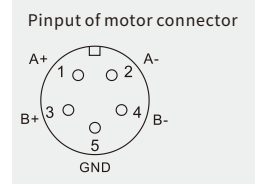

## Torque-frequency curve

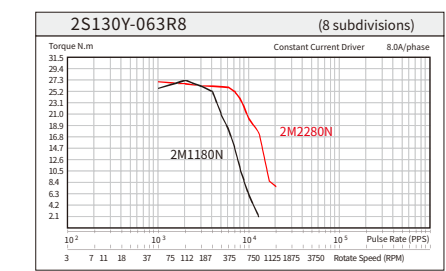
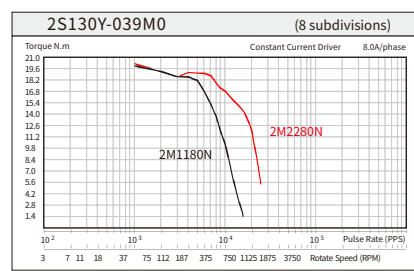

# Three-phase stepper motor/57 series

# Three-phase stepper motor/85 series

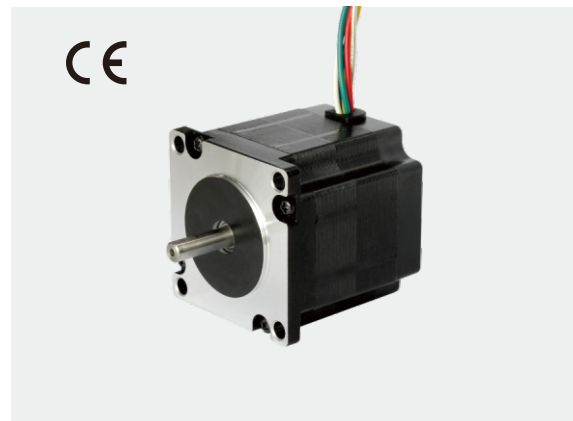

## Dimensions (Unit:mm)

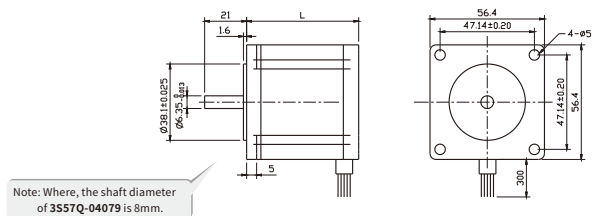

Note: Where, the shaft diameter of 3S57Q-04079 is 8mm.

## Specification

Technical Specifications	3S57Q-04079	3S57Q-04056
Step angle	1.2°	1.2°
Phase current (A)	5.8	5.6
Holding torque (Nm)	1.5	0.9
Damping torque (Nm)	0.07	0.04
Winding resistance (Ω)	1.05±10%	0.7±10%
Winding inductance (mH)	2.4±20%	1.7±20%
Motor inertia (kg.cm <sup>2</sup> )	0.48	0.3
Motor length L (mm)	79	56
Shaft diameter (mm)	8	6.35
Number of lead wires	6	
Insulation class	B	
Withstand voltage level	600VAC 1S 5mA	
Max. axial load (N)	15	
Max. radial load (N)	75	
Operating temperature	-20°C~+50°C	
Surface temperature rise	Max.80°C (Working with rated phase current)	
Insulation impedance	Minimum 100MΩ, 500V DC	
Weight (kg)	1	0.72
Startup freq. with no load(Hz)*	2.1K	2.4K
Ingress protection	IP40	

Note: The startup freq. is tested under condition of 2000 steps/round, only for reference.

## Motor cable



## Torque-frequency curve

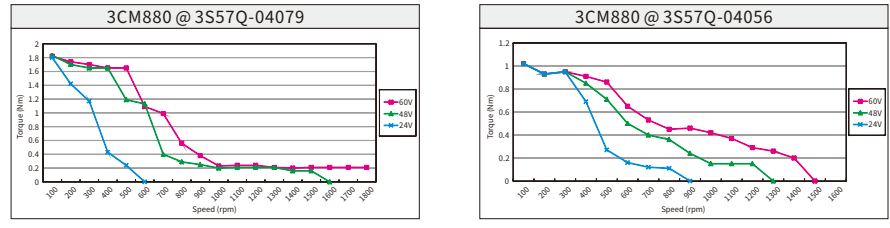

## Dimensions (Unit : mm)

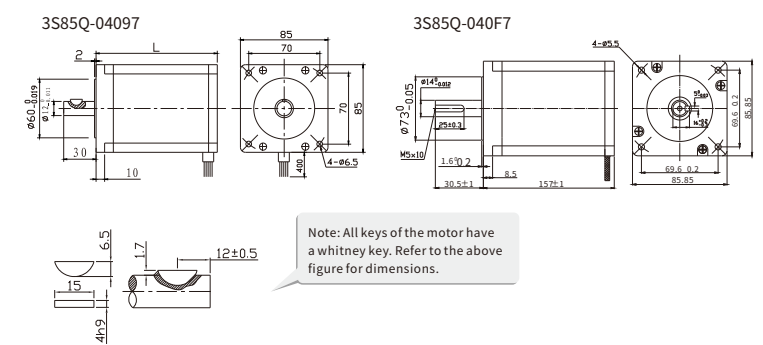
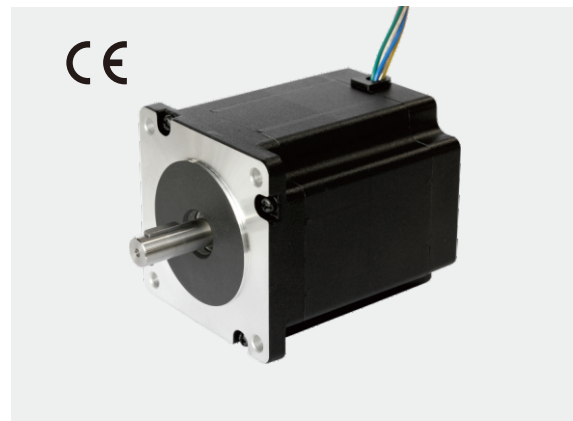

Note: All keys of the motor have a whitney key. Refer to the above figure for dimensions.

## Specification

Technical Specifications	3S85Q-04097	3S85Q-040F7
Step angle	1.2°	1.2°
Phase current (A)	5.8	4
Holding torque (Nm)	4.0	7.5
Damping torque (Nm)	0.12	0.36
Winding resistance (Ω)	1.1±10%	1.78±10%
Winding inductance (mH)	4.6±20%	17.1±20%
Motor inertia (kg.cm <sup>2</sup> )	2.32	0.44
Motor length L (mm)	97	157±1
Shaft diameter (mm)	12	14
Number of lead wires	6	3
Insulation class	B	B
Withstand voltage level	600VAC 1S 5mA	1800VAC 1S 5mA
Max. axial load (N)	60	60
Max. radial load (N)	220	220
Operating temperature	-20°C~+50°C	
Surface temperature rise	Max.80°C (Working with rated phase current)	
Insulation impedance	Minimum 100MΩ, 500V DC	
Weight (kg)	2.7	5.3
Startup freq. with no load(Hz)*	1.4K	2.0K
Ingress protection	IP40	

Note: The startup freq. is tested under condition of 2000 steps/round, only for reference.

## Motor cable



## Torque-frequency curve

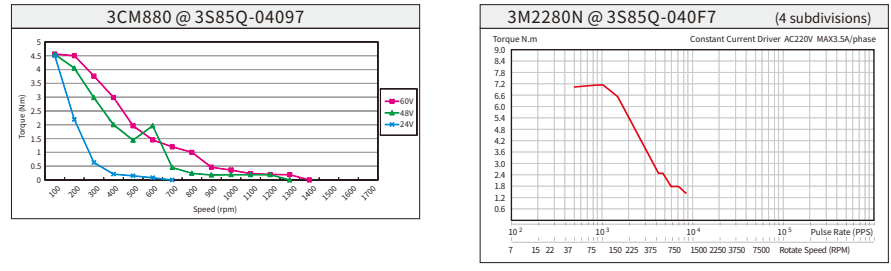



Motion Mode	Rotational Motion	Linear Motion	
		Horizontal axial direction	Vertical axial direction
Mechanical structure			
	Nt: Drive speed (r/min) Vt: Load speed (m/min) Tl: Load torque (N·m) mu: Friction coefficient P_B: Screw lead (m)	M: Quality of linear motion part (kg) M_C: Weight quality (kg) 1/R: Gear reduction ratio eta: Friction coefficient	
Speed curve			
Single travel(m)	$l = \frac{V_t}{60} \cdot t_0 + t_1$		
Drive speed(rpm)	Nt	$N_t = \frac{V_t}{P_B}$	$N_t = \frac{V_t}{P_B}$
Rotational speed of motor(rpm)	$N_m = N_t \cdot R$		
Load torque(N·m)	$T_l = \frac{T_l}{R \cdot \eta}$	$T_l = \frac{\mu \cdot g \cdot M \cdot P_B}{2\pi \cdot R \cdot \eta}$	$T_l = \frac{g \cdot (M - M_C) \cdot P_B}{2\pi \cdot R \cdot \eta}$
Load Inertia (kg·m <sup>2</sup> )	$J_l = J_{L1} + J_{L2} + J_{L3}$		
	Linear motion	$J_{L1} = M \cdot \left(\frac{P_B}{2\pi R}\right)^2$	$J_{L1} = (M + M_C) \cdot \left(\frac{P_B}{2\pi R}\right)^2$
Rotational motion	· Solid Cylinder: $J_k = \frac{\pi}{32} \cdot L \cdot D^4$ density: iron $\rho = 7.9 \times 10^3 \text{ (kg/m}^3\text{)}$ Aluminum: $\rho = 2.7 \times 10^3 \text{ (kg/m}^3\text{)}$ Brass: $\rho = 8.5 \times 10^3 \text{ (kg/m}^3\text{)}$ Nylon: $\rho = 1.1 \times 10^3 \text{ (kg/m}^3\text{)}$		
	· Hollow Cylinder: $J_k = \frac{\pi}{32} \cdot L \cdot (D_o^4 - D_i^4)$ Inertia loaded to motor shaft Gear input: $J_{L2} = J_k$ Gear output: $J_{L3} = \frac{J_k}{R^2}$		
Start torque(N·m)	$T_s = \frac{2\pi \cdot N_m (J_m + J_l)}{60 \times t_1}$ $J_m$ indicates the inertia of the motor rotor (Unit: kg·m <sup>2</sup> )		
Necessary torque(N·m)	$T_m = (T_l + T_s) \times S$ $S$ indicates the safety coefficient, normally 2~3		

## Model Selection Procedure

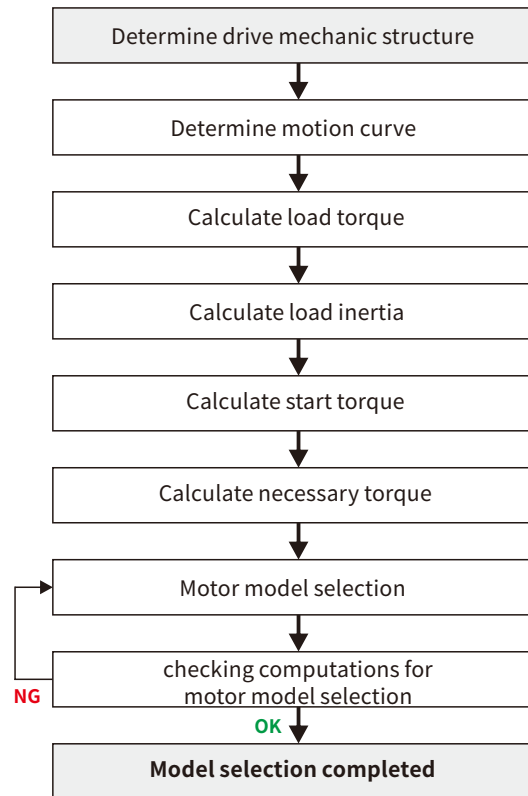

## Example for Model Selection

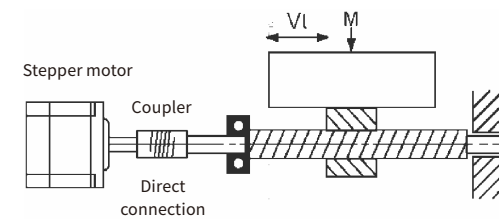

Speed:  $V_t = 1.5 \text{ m/min}$   
 Quality of slide part:  $M = 50 \text{ kg}$   
 Screw length:  $L_B = 1.4 \text{ m}$   
 Screw diameter:  $D_B = 0.012 \text{ m}$   
 Screw lead:  $P_B = 0.004 \text{ m}$   
 Coupler quality:  $M_C = 0.2 \text{ kg}$   
 Outer diameter of coupler:  $D_C = 0.04 \text{ m}$   
 Friction coefficient:  $\mu = 0.3$   
 Movement distance:  $l = 0.0275 \text{ m}$   
 Motion time:  $t_0 = 1.2 \text{ s}$   
 Mechanical efficiency:  $\eta = 0.9$

### (1) Speed curve

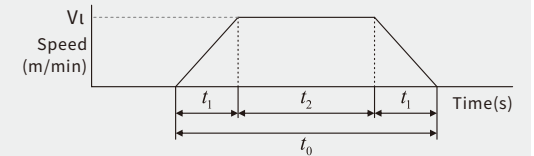

$$\text{Acceleration time: } t_1 = t_0 \cdot \frac{1}{1.2} = \frac{0.0275}{1.5 \div 60} = 0.11 \text{ (s)}$$

### (2) Rotation speed of motor

$$N_m = \frac{V_t}{P_B} = \frac{1.5}{0.004} = 375 \text{ (rpm)}$$

### (3) Load torque

$$T_l = \frac{\mu \cdot g \cdot M \cdot P_B}{2\pi \cdot R \cdot \eta} = \frac{0.3 \times 9.8 \times 50 \times 0.004}{2\pi \times 0.9} = 0.104 \text{ (N·m)}$$

### (4) Load inertia

Linear motion:  $J_{L1} = M \cdot \left(\frac{P_B}{2\pi}\right)^2 = 50 \times \left(\frac{0.004}{2\pi}\right)^2 = 2 \times 10^{-4} \text{ (kg·m}^2\text{)}$   
 Ball screw:  $J_B = \frac{\pi}{32} \cdot \rho \cdot L_B \cdot D_B^4 = \frac{\pi}{32} \times 7.87 \times 10^3 \times 1.4 \times (0.012)^4 = 0.224 \times 10^{-4} \text{ (kg·m}^2\text{)}$   
 Coupler:  $J_C = \frac{1}{8} \cdot M_C \cdot D_C^2 = \frac{1}{8} \times 0.2 \times (0.04)^2 = 0.4 \times 10^{-4} \text{ (kg·m}^2\text{)}$   
 Load inertia:  $J_l = J_{L1} + J_B + J_C = 0.824 \times 10^{-4} \text{ (kg·m}^2\text{)}$

### (5) Motor torque

Start torque:  $T_s = \frac{2\pi N_m (J_m + J_l)}{60 t_1} = \frac{2\pi \times 375 \times (J_m + 0.824 \times 10^{-4})}{60 \times 0.1} = 0.032 + 392.5 J_m \text{ (N·m)}$   
 Necessary torque:  $T_m = (T_l + T_s) \times S = (0.104 + T_s) \times 2 = 0.272 + 0.08 \times 10^4 J_m \text{ (N·m)}$   
 $S$  indicates the safety coefficient, normally 2.  
 $J_m$  indicates the inertia of the motor rotor (Unit: kg·m<sup>2</sup>).

### (6) Motor selection

Based on the above calculation, preliminarily this motor model is selected, i.e., 2S56Q-02741.

Rotor inertia:  $J_m = 0.135 \times 10^{-4} \text{ kg·m}^2$   
 $T_m = 0.272 + 0.08 \times 10^4 \times 0.135 \times 10^{-4} = 0.283 \text{ (N·m)}$

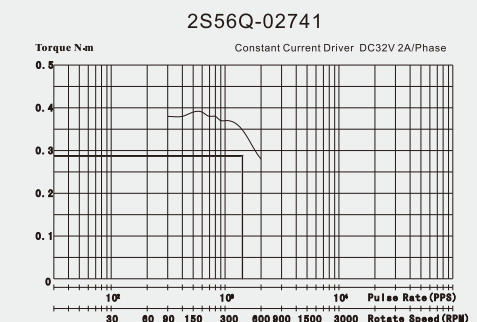

Refer to the torque-frequency curve of 2S56Q-02741. The output torque of the motor meets the requirements, so this motor is selected.

## Installation Direction

There is no limitation for the installation direction of motors, but normally motors are horizontally installed. They also support vertical downward or upward installation. Regardless of the installation direction of motors, please do not apply excessive vertical or horizontal load the shaft of a motor.

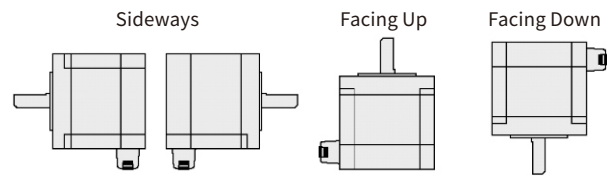

## Installation

Please install the motor closely on a metallic surface with perfect heat conductivity.

## Recommended Motor Installation Position

Motors shall be installed in positions meeting the following conditions:

1. Indoor;
2. The temperature inside the control cabinet shall range from  $-10^{\circ}\text{C}$ ~ $+50^{\circ}\text{C}$  (non-freezing);
3. The humidity inside the control cabinet shall be less than 85% (non-condensing);
4. Free from erosive gases or dust;
5. Free from water or oil (if available, please install a sheath);
6. Perfect ventilation and heat dissipation.

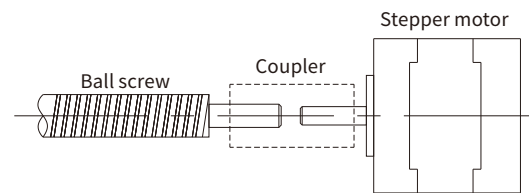

Note :

- Do not disassemble the motor;
- Do not apply any impact to the motor shaft;
- Do not install the motor in a place where it might bear long-term vibration, so as to avoid any possible damage to the motor shaft.

## Aligned Connection of Load

When a load is connected to the motor shaft, make sure that the load shaft aligns with the motor shaft. It is recommended that an anti-backlash flexible coupler or other appropriate devices are used to meet this requirement. Mechanical processing is forbidden for the motor shaft. Please contact your supplier if it is really necessary.

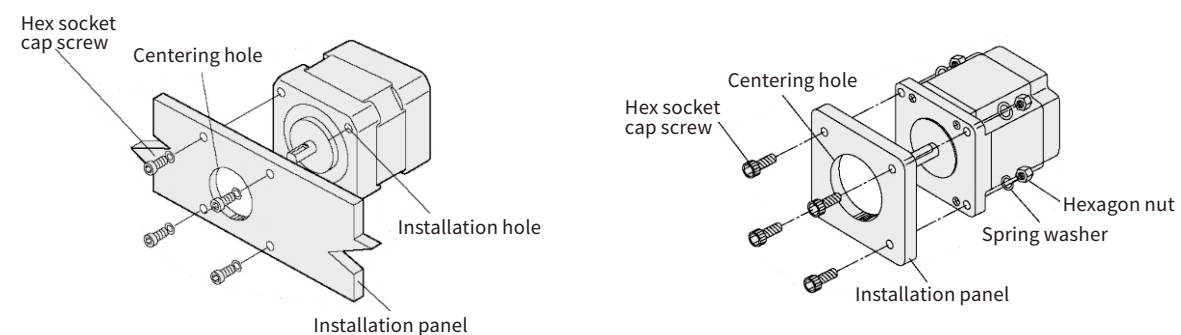

## 1. General Connection Mode of Control Signal

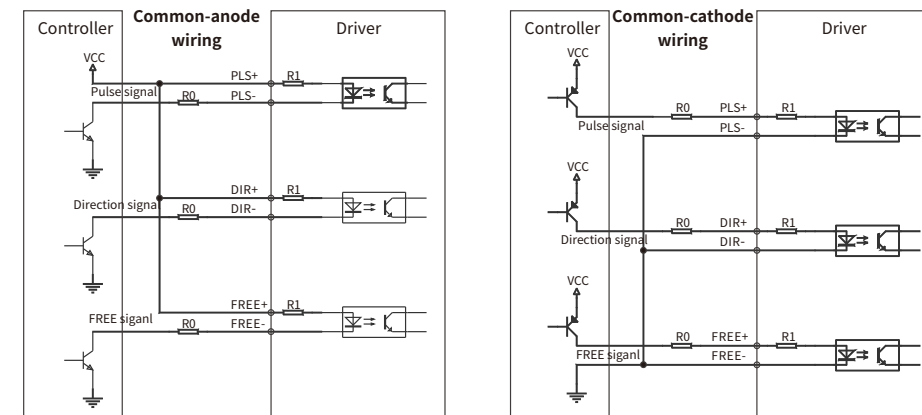

## 2. Twisted-pair Connection Mode of Control Signal

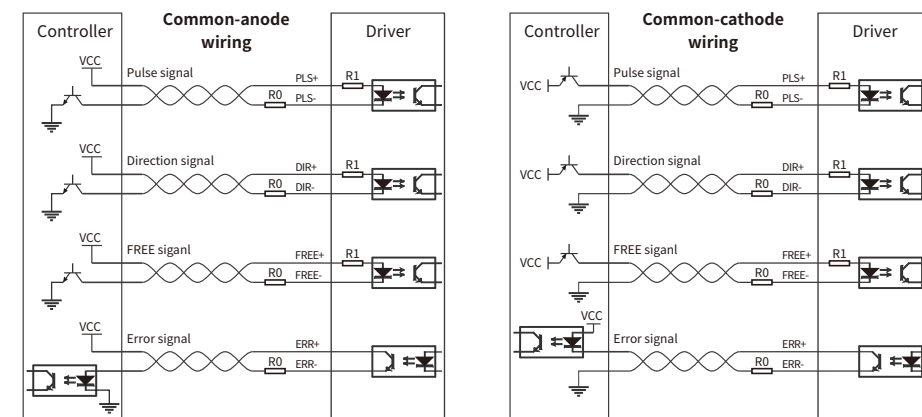

- Note: 1. For 2CM525, 2CM545, 2CM560, 2CM860, 2CM880, 3CM880, CM880A, 2H1160, FM860, there is no need to connect 2K ohm resistor in the wiring,  $R_0=0$ ;
2. For 2M412, 2M1180N, 2M2280N, 3M2280N, 2K ohm resistor is required to be connected serially,  $R_0=2\text{K ohm}$ .

## 3. Signal control sequence

